

Translation of the
original operating manual

- English -

MobiSet 4 digital **CAP 910**



KATHREIN
Antennen • Electronic

GENERAL

Dear Customer, Chère Cliente, Cher Client, Gentile cliente, Estimado cliente,

GB

You can obtain an English version of our mounting instructions from our representatives in your country (http://www.kathrein.de/include/kontakte_groups_eng.cfm?kontinent=1&gruppe=SAT) or download one from our homepage (<http://www.kathrein.de/en/sat/index.htm>).

F

Vous pouvez obtenir un manuel d'installation en français chez notre représentant en votre pays (http://www.kathrein.de/include/kontakte_groups_eng.cfm?kontinent=1&gruppe=SAT) ou le télécharger de notre page d'ouverture (<http://www.kathrein.de/en/sat/index.htm>).

I

Lei può avere la versione italiana delle istruzioni di montaggio dalla nostra rappresentanza (http://www.kathrein.de/include/kontakte_groups_eng.cfm?kontinent=1&gruppe=SAT) più vicina della sua città, oppure scaricarla dalla nostra homepage (<http://www.kathrein.de/en/sat/index.htm>)

E

Para obtener la versión española de nuestro manual de instalación, contacte nuestros representantes en su país (http://www.kathrein.de/include/kontakte_groups_eng.cfm?kontinent=1&gruppe=SAT) o bajela de nuestra página de Internet (<http://www.kathrein.de/en/sat/index.htm>).

COMPANY ADDRESS AND ACCREDITED REPRESENTATIVE

KATHREIN-Werke KG
Anton-Kathrein-Straße 1 - 3
P.O. Box 100 444
83022 Rosenheim GERMANY

Prof. Dr. Dr. h. c. Kathrein,
MBA
Personally liable
Managing Director of KATHREIN-Werke KG

MOBISET 4 CAP 910 COMPONENTS / SCOPE OF DELIVERY

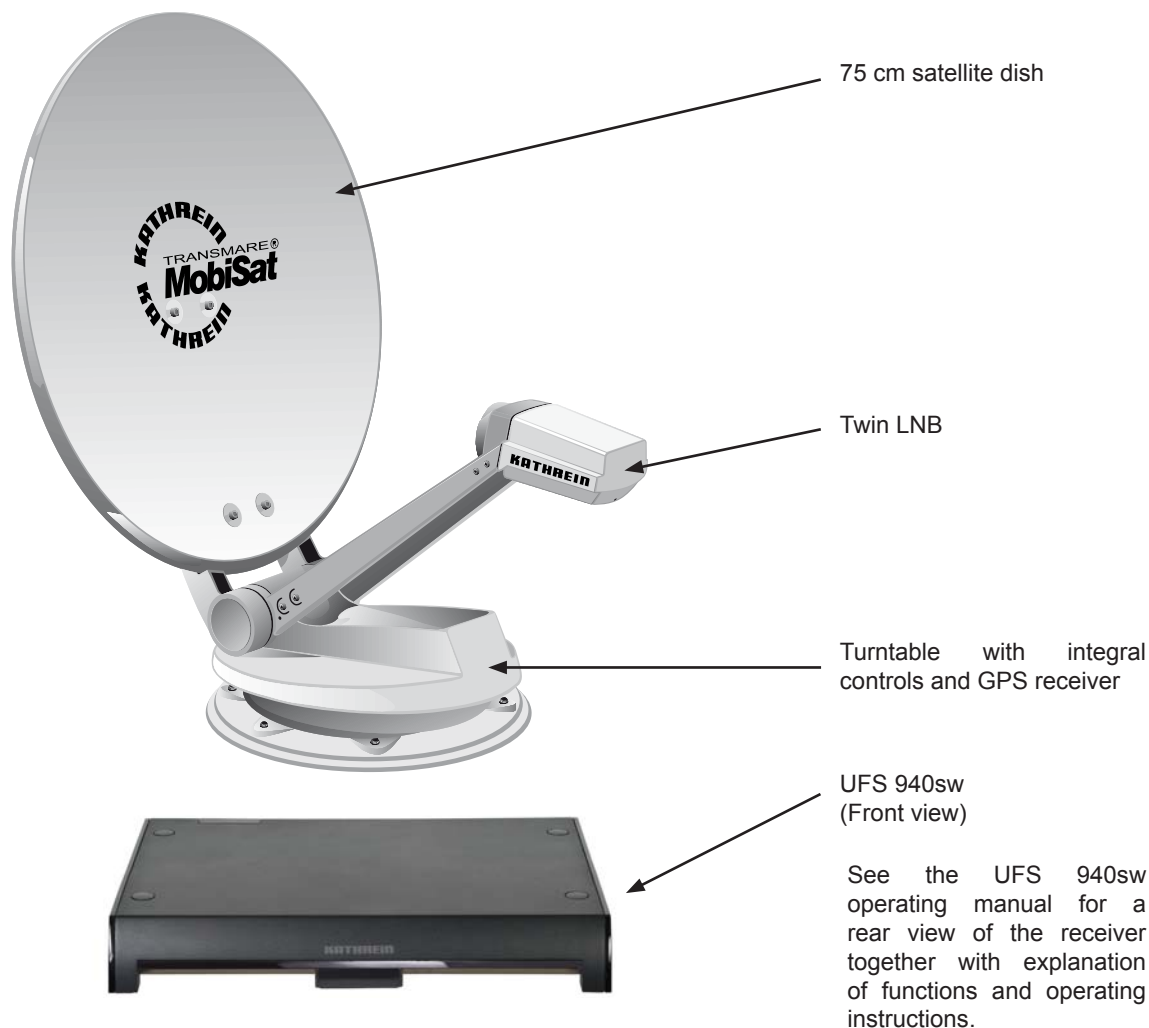

PRODUCT PACKAGE

The MobiSet 4 digital CAP 910 consists of:

- Turntable complete with control electronics (and GPS receiver), pre-assembled satellite dish and twin LNB
- Mounting plate
- Complete cabling set: 2 x coax cables each 8 m long, and one power supply cable (10 m) for connection to the on-board power supply
- Roof gland with sealing gasket
- Sikaflex® 291 adhesive sealant (100 ml tube)
- UFS 940sw HDTV-DVB-S receiver with connecting cables, infrared sensor and infrared remote control
- MobiSet 4 digital CAP 910 installation manual
- UFS 940sw satellite receiver operating manual

CONTENTS (INSTALLATION MANUAL)

GENERAL	2
MOBISET 4 CAP 910 COMPONENTS / SCOPE OF DELIVERY	3
CONTENTS	4
PROPER USE	6
SAFETY INSTRUCTIONS - IMPORTANT NOTES	7
INSTALLATION AND CONNECTION	10
INSTALLATION OF CABLE GLAND AND MOUNTING PLATE.....	12
INSTALLATION OF TURNTABLE	14
INSTALLATION OF THE UFS 940SW	18
LAYING CABLES AND CONNECTING THE TURNTABLE	23
CONNECTING TO THE UFS 940SW	23
FUNCTIONAL INSTRUCTIONS FOR CONNECTION TO THE ON-BOARD POWER SUPPLY.....	24
CONNECTION EXAMPLE FOR 12 V BATTERY CONNECTION	25
RECEPTION RANGE / FOOTPRINT	26
DISMANTLING FOR SERVICING	27
DISMANTLING	27
ADDRESS OF THE SERVICE CENTRE.....	27
MANUAL LOWERING TO PARK POSITION	28
SAFETY INSTRUCTIONS.....	28
MANUAL LOWERING.....	29
TECHNICAL SPECIFICATIONS	30
SIKAFLEX® 291 SAFETY DATA SHEET	31
SIKAFLEX® 291 TECHNICAL DATA SHEET	36

CONTENTS (OPERATING MANUAL)

CAP 910 OPERATING MANUAL	38
IMPORTANT INFORMATION FOR CAP 910 BEFORE SETUP	39
REMOTE CONTROL	39
FIRST INSTALLATION	40
CAP MENU (TURNTABLE ANTENNA SETTINGS)	44
CALLING UP THE CAP MENU	44
RESETTING THE CAP SYSTEM (TURNTABLE ANTENNA) (RESET).....	44
INPUTTING THE CAP GPS POSITION	45
TO MOVE THE ANTENNA MANUALLY	45
ELEVATION.....	45
LNB TILT/SKEW	46
STOP ON SIGNAL	46
MOVE TO THE AZIMUTH (ROTATE THE ANTENNA)	46
MOVE CAP TO PARK POSITION.....	47
CAP SETTINGS.....	47
ELEVATION BORDER AND ELEVATION OFFSET	47
SEARCH SPEED	47
COUNTDOWN FOR THE SEARCH START	48
RESTORE FACTORY SETTINGS	48
ALIGNMENT (SATELLITE SEARCH)	49
CHANNEL (SATELLITE) SELECTION/PROGRAMMING THE TIMER	50
CHANNEL SELECTION FROM THE CHANNEL LIST	50
CHANNEL SELECTION FROM THE CHANNEL LIST (SORTED BY SATELLITE).....	51
CHANGE OF LOCATION	52
PARK	54
PARKING THE TURNTABLE	54
SPECIAL MESSAGES FROM THE TURNTABLE	55
DECLARATION OF CONFORMITY	59
DISPOSAL INSTRUCTIONS	60

PROPER USE

PROPER USE (USE FOR THE INTENDED PURPOSE)

The MobiSet 4 digital CAP 910 is designed to receive digital TV and radio channels via satellite. The automatic positioner is intended to be used as a turntable for the Kathrein satellite dish. The turntable can be used to receive digital TV and radio signals in the frequency range from 10.70 to 12.75 GHz; the antenna cannot receive terrestrial signals (e.g. DVB-T).

The turntable can only be used in conjunction with the UFS 940sw/740sw DVB-S receiver.

In conjunction with these receivers, the turntable provides fully automatic alignment of the satellite dish to receive digital satellite signals. The turntable is designed for use on stationary caravans or motor homes.

Any use other than that specified above will invalidate the warranty or guarantee.

The following circumstances result in the loss of all warranty and liability claims towards the manufacturer:

- Improper installation
- Use of non-specified mounting materials, which cannot guarantee the mechanical reliability of the antenna system
- Impermissible use, e.g. use of the reflector dish for storage
- Structural changes or interference with the components and mounting accessories in the set, which could endanger both the mechanical and functional reliability
- Improper or forcible opening of the components
- Use of cleaners containing solvents, such as acetone, nitro-cellulose thinners, petrol etc.
- Failure to observe installation and safety instructions in this manual

Note: *The maximum permissible speed for vehicles with a CAP 910 receiver unit mounted on the roof is 130 km/h. Before commencing a journey, the antenna must always be lowered into horizontal position (park position).*



The turntable may be operated in an ambient temperature range of -20 °C to +45 °C. Operating the system outside this range may result in malfunctions or damage to the system. When choosing the location for installation or raising the UFS 940sw, ensure there is adequate ventilation.

The system may only be installed by qualified specialist personnel!

To prevent hazards during installation, operation or when driving on public highways, the instructions and information in this manual must be strictly adhered to. Proper installation and connection of the system are pre-requisites for conformity with the corresponding standards.

This is documented in advance by the CE mark and the declaration of conformity in the appendix to this manual.

SAFETY INSTRUCTIONS - IMPORTANT NOTES

Safety during installation work



When carrying out installation work in locations where there is a risk of falling, take appropriate safety precautions, e.g. use of a working platform. Make sure that the vehicle roof is sufficiently strong and stable to carry out the installation work (risk of damage or collapsing of roof).

In case of doubt, contact a qualified specialist dealer or the manufacturer of your vehicle to find an appropriate installation location.

Make sure that:

- The turntable and connected units are disconnected from the power supply
- The person carrying out the installation or repair does not suffer from vertigo and can move around safely on the roof of the caravan or motor home
- The person carrying out the installation or repair is wearing sturdy and non-slip shoes
- The person carrying out the installation or repair has a secure position to stand and hold on while working
- The roof and the climbing equipment used (e.g. ladder) are dry, clean and non-slip
- The roof can withstand the weight of the person carrying out the repairs

Caution! Risk of death or injury due to falling or the roof collapsing!

- Nobody should be inside the caravan/motor home underneath the antenna during dismantling/ installation

Caution! Risk of death or injury due to possible roof collapse and falling parts!

Proper installation and safety

Essential information

A crucial safety factor is proper performance of installation and electrical connection work, and the specified alignment of the turntable in the direction of travel (park position), see also installation and connection.

Comply as precisely as possible with the installation conditions and steps described.

Modifications to the electrical installations in the vehicle should only be carried out by a specialist in vehicle electrics. Do not make any unauthorised changes to the turntable.

Adhesive sealant

The turntable is attached to the roof of the vehicle by adhesive and is secured by additional screws.

Note that the curing of the adhesive sealant is temperature-dependent. It reaches its full strength only after approximately five days.



During installation work, comply strictly with the processing and safety instructions for the adhesive sealant (Sikaflex® 291 safety data sheet and Sikaflex® 291 technical data sheet).

SAFETY INSTRUCTIONS - IMPORTANT NOTES

Road Traffic Licensing Regulations (StVZO)

The applicable regulations of the StVZO must be observed in respect of fixed installation of the turntable on a vehicle which is driven on public highways.

In particular, §§ 19/2; 30 C; 32 (2) and the EC directive 74/483 EEC are applicable.

Briefly, they state that no endorsement of the vehicle documentation is required unless the antenna unit causes the height of the laden vehicle to exceed 2 m, or the antenna unit projects beyond the outer lateral outline of the vehicle. The maximum permissible height of 4 m (vehicle and antenna unit) may not be exceeded.



There is an increased risk of accidents if the normal vehicle height is increased by extending the antenna. The driver bears sole responsibility for the condition of the superstructure and external fittings!

Cables

Lay all cables such that nobody can tread on them or trip over them.

To prevent parasitic induction or interference emissions, when extending the antenna cable use 75 Ω coaxial cable with a screening factor of at least 75 dB.



If you tied the cables together with wire or similar materials, remove this to prevent the risk of fire!

When connecting the power cables (receiver and turntable) to the vehicle electrical supply, make sure that the cable polarity is not reversed.



If the cable polarity is reversed there is a risk of thermal overload and damage to components when the equipment is powered up!

Power supply, fusing

Operate the system from your vehicle's battery (12 V) or a suitable mains power supply unit. This power supply unit must ensure a stable output voltage of 12 V, continuous current of 11 A and 15 A (300 ms) surge current.

The transient power consumption is up to a maximum of 12 A.

To ensure reliable functioning of the connection/control unit, the power supply cable must be connected directly to the battery. If the supply voltage is too low, the UFS 940sw receiver indicates this with the on-screen message "On-board voltage too low" on the television screen.

A 15 A fuse is incorporated in the power supply cable. If the fuse blows, rectify the source of the fault and replace the blown fuse with a fuse of the same rated value (15 A).



Never remove or bypass the fuse in the cable – cable fire hazard!

Connecting the power supply cable lead marked "Ignition" activates the turntable function for automatic lowering of the antenna. This lowering takes place as soon as the vehicle ignition circuit is turned on. When connecting the control unit to the vehicle power supply, make sure that the "12 V", "Earth" and "Ignition" wires cannot be disconnected by intermediate switches, as this could deactivate the automatic lowering function.

SAFETY INSTRUCTIONS - IMPORTANT NOTES



The antenna will be lowered within 12 seconds of the ignition being switched on (if the unit is in stand-by mode or the UFS 940sw is switched off). Otherwise the control unit that is in use is lowered immediately.

Important: Lowering the antenna can take up to 30 seconds after the ignition is switched on!

Checks before commencing a journey

- Before commencing a journey, the antenna must always be lowered into horizontal position (park position). If the antenna has collided with a fixed or movable object, check that it is still securely attached.
- As the antenna is subjected to vibration loads during driving, you should check at regular intervals, depending on the frequency of driving, that the system is still securely attached and tighten any parts that have worked loose.
- The maximum permissible speed for vehicles with a receiver unit mounted on the roof is 130 km/h.
- Lower the antenna if it will not be used for a long period. This makes the securing bolts more difficult to access (protection against theft).

Antenna in the park position whilst driving

The antenna must always be lowered into horizontal position (park position) while driving. As a reminder, attach the sticker from the supplementary sheet “Lower the CAP 910 antenna while driving” where it can easily be seen by the person operating the ignition switch.



Safety precautions during operation

During operation of the turntable, make sure that no persons, in particular children, are in the immediate vicinity of the turntable and that they cannot touch any moving parts – crush hazard!

Always unplug the power supply during installation work.



Exceeding the normal vehicle height by failing to lower the antenna increases the risk of accidents! The driver is responsible for the condition of the superstructure and external fittings!



In addition the instructions in the installation and operating manuals for these devices and for the attachments and superstructures must be complied with at all times!



If stormy weather is expected, the turntable must always be moved to the park position, otherwise both the CAP 910 and the vehicle may be damaged.

INSTALLATION AND CONNECTION

REQUIRED TOOLS AND EQUIPMENT

- Circular cutter, Ø 38 mm
- Flat-bladed screwdriver for M5 screws
- Power drill
- Galvanised round head screws, depending on the roof structure (Ø: 5 mm, self-tapping screws D 7981, depending on roof panel structure) or round head screws D 7985 with shims and nuts
- Twist drill, Ø 2.5 or 5.5 mm
- Round file and/or emery paper
- Cleaning agent
- Open-ended or ring spanners 10 and 11 mm across flats
- Knife
- Cross-head screwdriver for M3 and M5 screws
- Torque wrench capacity 6 to 11 Nm
- Allen wrench (5 mm)
- Two wooden beams for supporting the turntable

UNPACKING AND PREPARATION

The CAP 910 must not be carried on the satellite dish, since this can cause the dish to distort. Keep the device in its cardboard box for transport on to the vehicle roof. Only take the turntable out of its packaging when it is on the vehicle roof. Retain the original packaging, as if it is necessary to send the unit for repair transport damage cannot be ruled out and the manufacturer accepts no liability for possible damage.

Loosen the six fastening screws (width A/F: 10 mm). Carefully lift the turntable off the mounting plate and place it on the two prepared wooden supports. Make sure that the cables are not crushed where they emerge from the underside of the turntable.

SELECTING THE INSTALLATION LOCATION

Essentially, the cable lengths of the MobiSet 4 CAP 910 components allow you a free choice of installation location on your caravan or motor home.

However, you should take note of the following points:

- Before installation, you should find out whether the operating manual for your vehicle permits the fitting of non-vehicle-specific parts or what requirements need to be met in order to do so.
- For direct satellite reception, there should be no obstructions between the antenna and the satellite. Therefore, make sure that the antenna is not shadowed by roof extensions such as luggage racks, air conditioning units, solar panels, etc. The problem of shadowing applies also to the selection of the parking place for your vehicle. For interference-free satellite reception, the antenna needs a projected free view to the South at an angle of between 15° and 55° (depending on location) to the horizontal.

INSTALLATION AND CONNECTION

- When selecting the installation position, take into account the range of movement of the turntable (see the grey shaded area in the graphics). Within this grey area there must be no structures on the roof that would obstruct this movement (risk of collision). For safety, keep at least the required area of 1024 x 1250 mm free (for ease of installation and any subsequent dismantling).

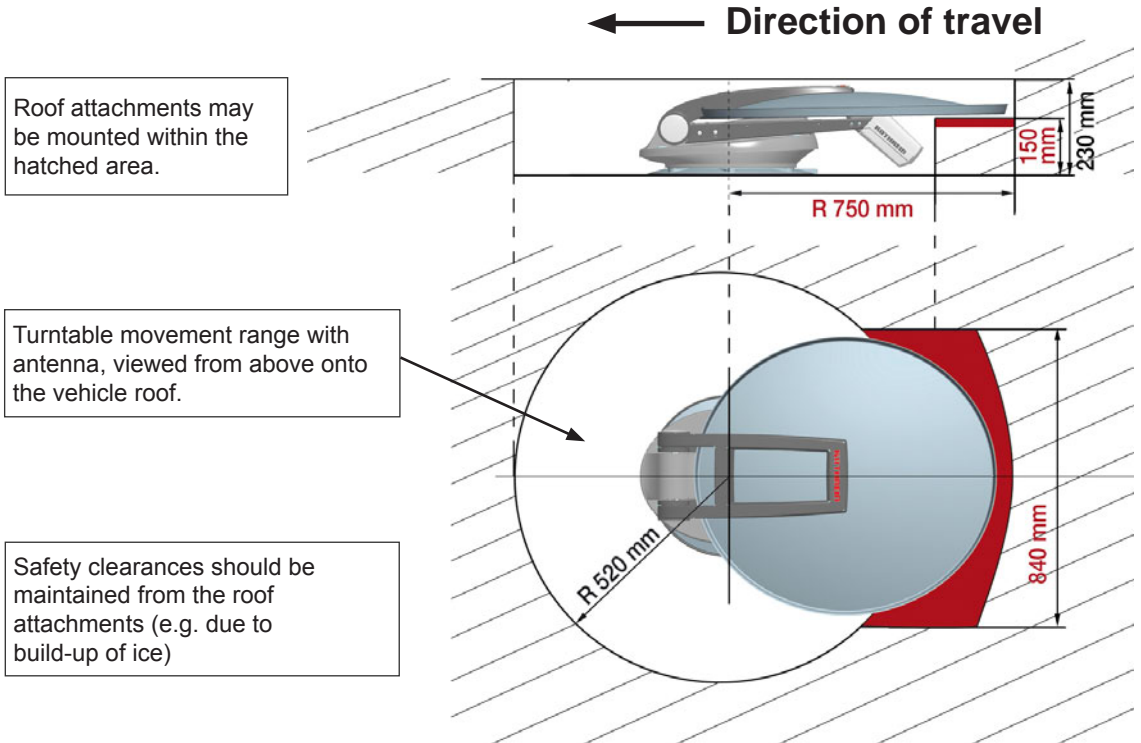

- Choose an installation position on the roof that is as flat as possible: depending on the location of the vehicle, roof pitches greater than 5° may lead to problems when searching for the satellite.
- To ensure secure adhesion, the height difference of the roof curve may not be more than 1 cm over a length of 2 m, as otherwise the gap between the roof and the mounting plate would be too great to be filled by the adhesive sealant.
- As the vehicle is constantly subjected to vibration loads during travel, the roof below the antenna unit is also subject to significant loads. Please note given the nature and capacity of your vehicle roof (see also operating manual for the vehicle) that the weight of the antenna unit is approx. 19 kg. In case of doubt, consult a qualified dealer or your vehicle's manufacturer.
- The roof gland provides a watertight seal through which the three connection cables (2 x coax cables, 1 x power supply cable) are fed into the interior of the vehicle directly underneath the turntable. If you prefer a different method of laying the cables, they can be run from the rear of the turntable via the channel provided in the mounting plate. The cables must then be run along the roof of the vehicle in a protective cable duct (not supplied). For the roof gland, use the HDZ 100 (BN 20410032) sealant available from specialist dealers as an accessory.

Note: Do not cut the cables short, as otherwise the proper functioning of the unit can no longer be guaranteed.

INSTALLATION AND CONNECTION

INSTALLATION STEPS

INSTALLATION OF CABLE GLAND AND MOUNTING PLATE

Note: If you had previously used a Kathrein HDM 140/141 jointed tripod mast or another mast with a diameter of 34 mm, you can continue using the existing through hole in the roof (if space allows).

Figure: A

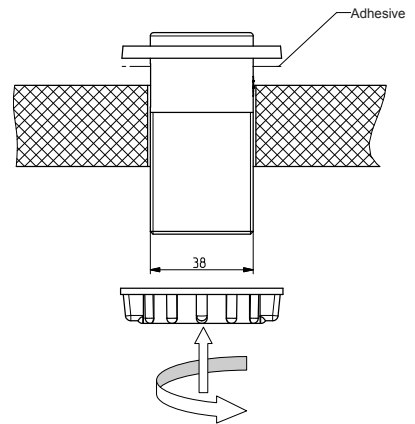

- In the centre of the intended position of the turntable, drill the opening for the cable gland with a circular cutter (\varnothing : 38 mm). Deburr the hole with a round file or emery paper.
- Provisionally insert the roof gland into the drilled hole (Fig. A).
- Place the mounting plate on the roof of the vehicle, such that the centre hole is positioned centrally to the cable gland. The **arrow symbol** must be visible from above and point **forwards in the direction of travel** (Fig. B).

Figure: B

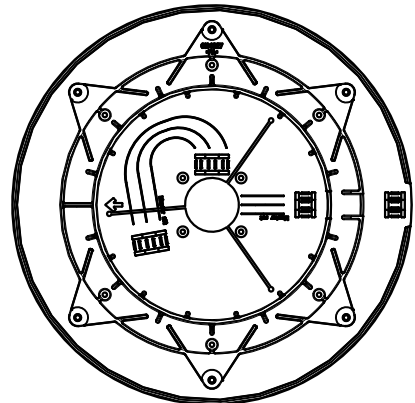

- Mark the positions of the ten fastening holes on the roof of the vehicle in a pitch circle.

Note: *The size of the holes and the choice of fastening screws to be used (not supplied) depend on the type and thickness of the materials used in the roof structure. If the roof panelling (plastic roofs) is sufficiently strong, it is recommended that round head screws, plain washers and self-locking nuts are always used to secure the glued mounting plate.*

INSTALLATION AND CONNECTION

- For very thin roof panel materials and insufficient support in the insulating material, through holes (\varnothing : 5.5 mm) into the interior of the vehicle are necessary; galvanised M5 round head screws of sufficient length should then be used.

Make sure that you use a sufficiently strong support that can withstand the bolt tensile forces (large plain washer or a complete reinforcing plate).

Figure: C

*) Not included

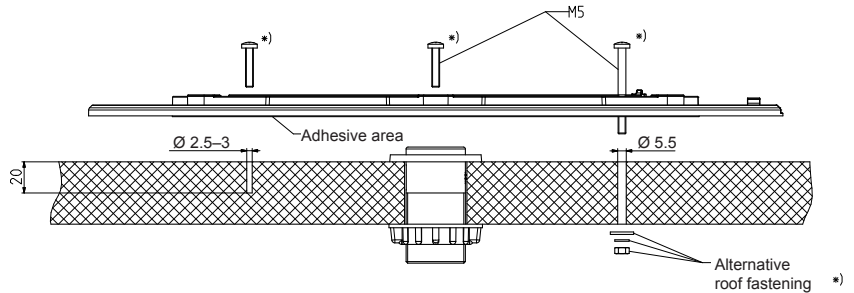

- Create the holes necessary to secure the mounting plate (Fig. C).
- In addition to the bolted connection, the mounting plate and roof gland must be bonded to the roof with adhesive and sealed. This is done using the Sikaflex[®] 291 adhesive sealant supplied, which is ideally suited for this purpose thanks to its broad range of adhesion.

Before starting to use Sikaflex[®] 291 adhesive sealant, be sure to read the Sikaflex[®] Products safety data sheet and technical data sheet in this installation manual!

The prerequisite for good adhesive characteristics is a clean, dry and grease-free substrate. You should therefore clean the roof surface with a suitable cleaning agent within a circumference of 17 cm around the drilled hole and allow the surface to dry thoroughly.

If the surface is painted, ensure that the paint finish is sufficiently well bonded to the substrate.

If the coat of paint is already loose or peeling, it must be removed down to a stable layer in the area to which the adhesive will bond. If you have any doubts concerning the adhesive characteristics, consult a paint and lacquer specialist, or the manufacturer of your vehicle.

Under certain circumstances, it may be necessary for you to improve the adhesive properties of the roof surface by pre-treatment with a cleaning agent available from specialist dealers (e.g. Sika[®] Cleaner) or a primer (e.g. Sika[®] Primer).

The procedure for gluing the mounting plate is as follows:

Figure: D

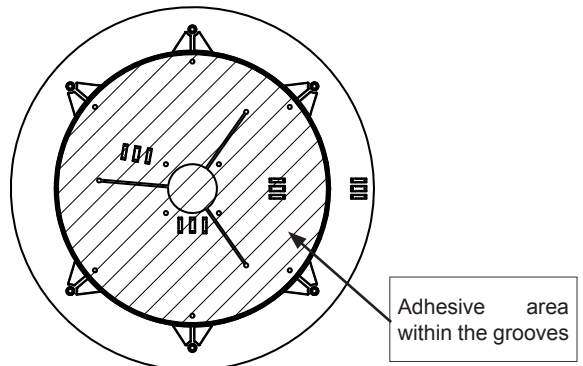

INSTALLATION AND CONNECTION

- Before starting adhesive work, note that the optimum processing temperature of materials to be glued and the sealant is between +15 °C and +25 °C. Prepare all necessary fastening elements and tools.
- Prepare the tube of adhesive sealant in accordance with the instructions enclosed with the tube.
- Remove the roof gland (Fig. A) and apply the adhesive sealant evenly to the underside of the roof gland flange.

Replace the roof gland in the drilled hole and press it firmly against the roof of the vehicle.

- Apply the adhesive sealant evenly to the underside of the mounting plate, completely covering the area within the circular groove (Fig. D).

This area of the vehicle roof must be completely coated with adhesive in order to achieve the necessary bonding force.

Place the mounting plate onto the roof of the vehicle, as you did previously when marking out the drilled holes.

Make sure that the arrow on the mounting plate points forward in the direction of travel.

The fastening holes must be perfectly aligned with the prepared holes in the roof.

- Fasten the mounting plate in place with the prepared screws, evenly tightening all ten screws across the diagonals.

Note: *The adhesive sealant used is capable of filling small gaps caused by the curvature of the vehicle roof. However, you should ensure that the mounting plate is not bent by tightening the screws.*

- Remove any adhesive sealant that leaks out at the sides with a clean cloth or if necessary with Sikaflex® remover (available from specialist dealers). Do not use cleaning agents or thinners containing solvents, as this could damage the sealant applied under the mounting plate. Use only cleansing paste and water to clean your hands.
- Secure the cable gland from inside the vehicle by tightening the ribbed nut supplied (Fig. A).
- Note that the curing of the adhesive sealant depends on the ambient temperature and the humidity. Final strength is reached only after approx. five days. However, this need not restrict further installation work, since the mounting plate is held in place by the tightened screws.

INSTALLATION OF TURNTABLE

VARIANT WITH CABLE GLAND UNDERNEATH THE TURNTABLE

- Lay the cables supplied with the turntable (2 x coaxial cables and 1 x power supply cable) into the mounting plate as indicated by the markings on the mounting plate (see Fig. E1), and feed the remaining lengths of cable through the roof gland into the interior of the motor home/caravan.

INSTALLATION AND CONNECTION



Figure: E1

Master coaxial cable
(marked red)

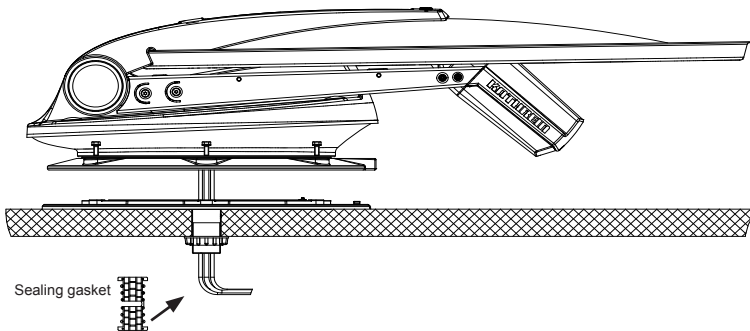

Figure: E2

- Lift up the turntable and place it carefully on the mounting plate facing in the direction of travel (see illustrations Fig. E) (do not step on the plug connectors and do not kink/crush the cables!)
The through holes on the turntable must be perfectly aligned with the threaded holes on the mounting plate.
- Allow the turntable to rest on the front edge of the mounting plate. Keep the turntable supported at an angle (see Fig. E1) and insert a suitable piece of wood underneath it.
- Now lay and connect the turntable cables in the mounting plate (as indicated on the mounting plate, see Fig. E1). Take particular care that the two master coaxial cables, marked red, are connected to each other. Initially tighten the coaxial cable plugs finger-tight, using no tools, then tighten them lightly using an open-ended 11 AF spanner.
- Now lower the turntable back on to the mounting plate, taking care whilst so doing that the cables are fed through the cable gland and are not snagged.
- Apply a little adhesive sealant to the six threaded holes in the mounting plate and screw the fastening screws into the thread. Tighten the screws to a torque of 6 Nm.

INSTALLATION AND CONNECTION

- To prevent water vapour from inside the vehicle reaching the turntable through the roof gland, thread the three cables through the sealing gasket supplied (see Fig. E2), close the gasket and insert it into the roof gland until it reaches the stop. Make sure that no tensile load is acting downwards on the sealing gasket as this can cause it to fall out in the course of time.

VERSION WITH EXTERNAL CABLE GLAND (FIG. F)

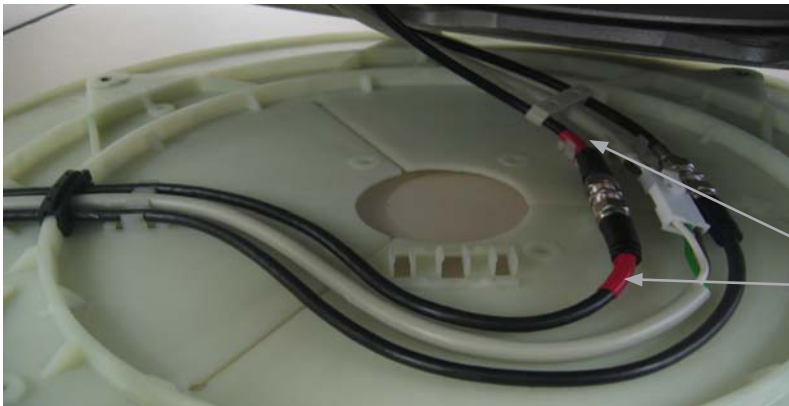
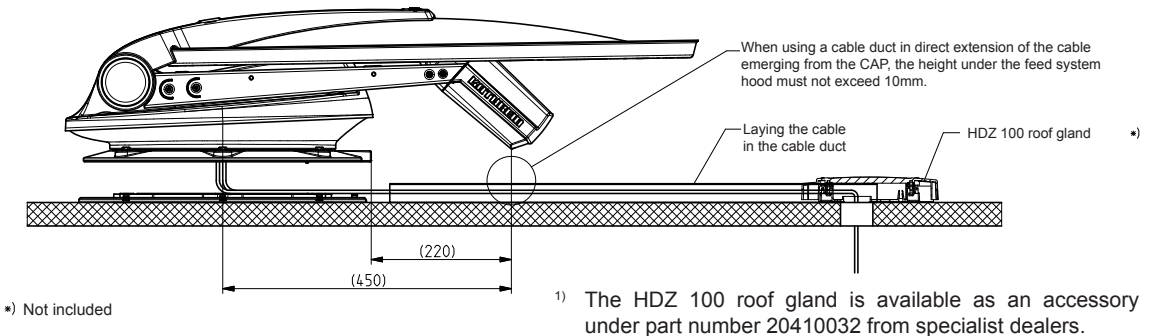

Figure: F1

Master coaxial cable
(marked red)

Figure: F2



- Lay the cables supplied with the turntable (2 x coaxial cables and 1 x power supply cable) into the mounting plate as indicated by the markings on the mounting plate (see illustrations in Fig. F), and feed the remaining lengths of cable through a cable duct*) and a roof gland¹⁾ into the interior of the motor home/caravan.
- Lift up the turntable and place it carefully on the mounting plate facing in the direction of travel (see illustration Fig. F2) (do not step on the plug connectors and do not kink/crush the cables!)

The through holes on the turntable must be perfectly aligned with the threaded holes on the mounting plate.

- Allow the turntable to rest on the front edge of the mounting plate. Keep the turntable supported at an angle (see Fig. F1) and insert a suitable piece of wood underneath it.
- Now lay and connect the turntable cables on the mounting plate (as indicated on the mounting plate, see also Fig. F1). Make sure that the cables are not crossed over and that they are taut so that they cannot be crushed. The two master coaxial cables, marked red, must be connected to each other.

INSTALLATION AND CONNECTION

Initially tighten the coaxial cable plugs finger-tight, using no tools, then tighten them lightly using an open-ended SW 11 spanner. Do not try to pull the cables from the unit. This could damage the cables or loosen the cable connections.

- Apply a little adhesive sealant to the six threaded holes in the mounting plate and screw the fastening screws into the thread.

Tighten the screws to a torque of 6 Nm.

- Run the connecting cables through the waterproof HDZ 100¹⁾ roof gland into the interior of the vehicle. In so doing the cables may not be crushed, kinked or damaged.



The connecting cables between the turntable and the connecting/control unit may not be extended!

- ¹⁾ The HDZ 100 roof gland is available as an accessory under part number 20410032 from specialist dealers.

INSTALLATION AND CONNECTION

INSTALLATION OF THE UFS 940SW

SELECTION OF A SUITABLE INSTALLATION LOCATION

Note: *When choosing the installation location, bear in mind that the rear of the unit should always be accessible. The UFS 940sw is equipped with a power saving circuit and a separate infrared transmitter, which means that the unit does not need to be placed where it is visible. You can therefore fit the UFS 940sw out of sight in any location, e.g. on cupboard walls, side walls or the base of storage compartments.*

The four screw sockets provided (see diagram on the next page) allow you to install the receiver not only resting on a shelf but also to fix it there or in other positions.

In addition, the following points should be taken into account:

- The wall thickness at the installation location must be at least 15 mm, as otherwise the screws will break through on the other side or damage the surface
- Ensure that the cupboard or storage compartment in which the unit is to be housed is adequately ventilated to prevent a build up of heat. Carpet-covered walls are unsuitable for installation
- Take care when tightening the screws not to damage any cables etc. behind or in the wall
- The receiver is designed exclusively for installation in dry, interior locations. The installation location must be protected against moisture
- The cable lengths must be taken into account when choosing the installation location
- The connecting cables must be provided with strain reliefs

Ventilation:

The heat generated within the receiver can be dissipated from the following sides of the casing: bottom, left, right and top. When selecting the installation location, make sure that these sides are not obstructed or covered. If the unit is operated continuously with insufficient ventilation, this can negatively affect the length of its working life!

Maintain a clearance of at least 20 cm above or below the unit, 2 cm to either side and 5 cm behind it, to allow unobstructed dissipation of the heat generated.

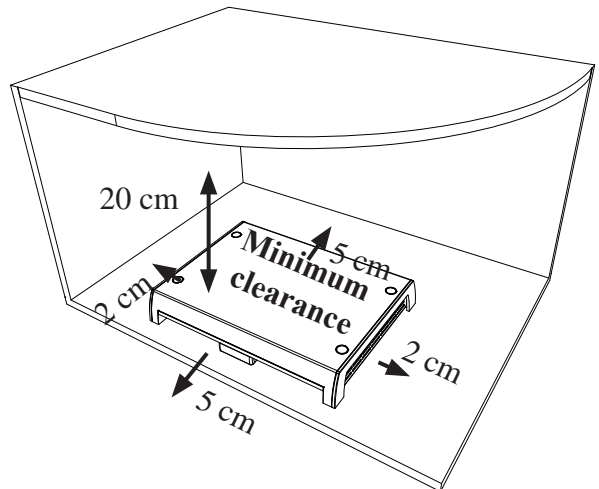

The unit monitors its temperature in operation. Premature failure of the unit due to continuous operation at temperatures higher than the recommended operating temperature as a result of insufficient ventilation does not constitute grounds for a claim under warranty/guarantee.

INSTALLATION AND CONNECTION

Connections and fusing of the unit:

All connection cables for connection to the receiver (including the infra-red sensor) are connected at the rear of the unit (see also the item "Connection example" in this section). When selecting the installation location, allow sufficient clearance at the rear of the unit for these cables and their plugs.

On the left hand side of the receiver viewed from the front there is a fuse inserted from the outside. This fuse (for the type, see the section "Important Information" in the receiver operating manual) should be accessible even after the unit has been installed, so that it can easily be exchanged if required.

PREPARATIONS

Removing the blanking plugs:

When the unit is delivered, the screw sockets are covered with blanking plugs. These can be pushed out, using the screws supplied (working upwards from below, see diagram on the right).

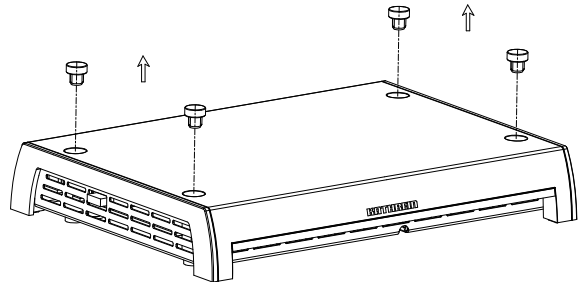

Attaching the infra-red sensor:

If the unit is installed in open view, you can attach the infra-red sensor directly to the unit; or if the receiver is installed in a concealed location, you should position the infra-red sensor where it can be clearly seen by the remote control unit. There are three places on the infra-red sensor where the adhesive strips supplied can be attached (see diagram on the right ①, ② and ③). The attachment point ① is provided for sticking the infra-red sensor directly to the unit.

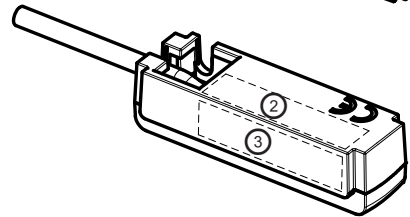
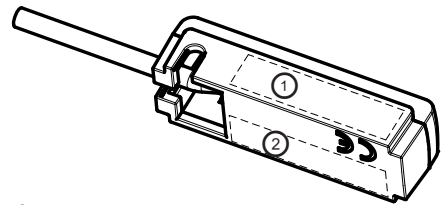

The attachment point on the receiver is on the front panel (see diagram on the right ④).

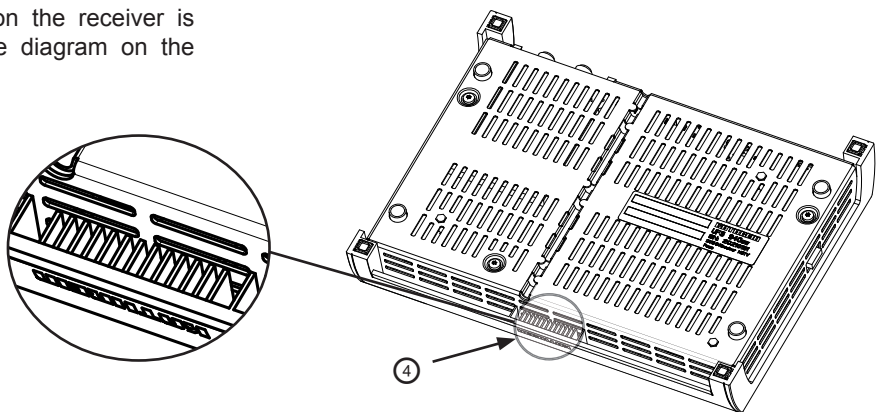

INSTALLATION AND CONNECTION

Using the adhesive strips supplied, now install the infra-red sensor either on the receiver or at the chosen location. If the infra-red sensor is installed on the unit, its cable can be threaded in at its base, as for a phone, and routed to the rear of the receiver (see diagram on the right).

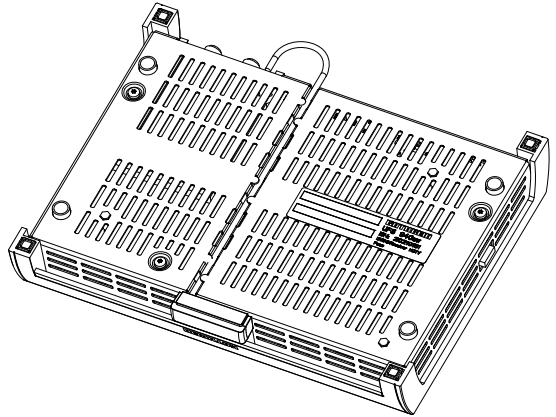

When threading in the cable, take care not to damage its sheath.

IMPORTANT INSTRUCTIONS FOR INSTALLATION



Under no circumstances use countersunk-head screws for installation (see diagram on the right), since these can damage the screw sockets on the receiver. Wherever possible, use the wood screws supplied with the receiver.



Before installing the receiver so that it is attached to another piece of equipment (such as a TV set), check with the manufacturer of that equipment or by reference to the documentation supplied with it whether this is permissible, and if so what fittings (screws etc.) you need/can use for this. The temperature rise of each of the units in operation (receiver/TV set) can in some circumstances affect the other unit.



The wood screws supplied with the receiver should not under any circumstances be used to attach it to a TV set or other electrical equipment! This could damage that equipment, possibly beyond repair.

Risk of fatal injury due to electric shock!

Use of other screws:

If because of the installation location or factors associated with it, the screws supplied cannot be used, refer to the diagram alongside when selecting the screws to be used. This shows you the cross-section area of the screw sockets on the receiver and shows which screws (diameter, screw head profiles etc.) can be inserted into the receiver support.

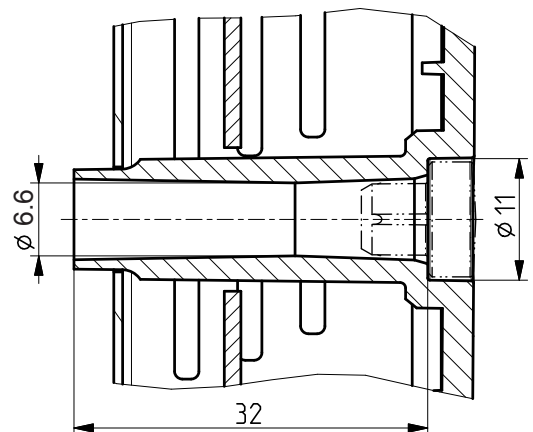

INSTALLATION AND CONNECTION

Useful information for installing the receiver on a TV set:

For installation by attachment to the rear of a TV set, securing with two screws is sufficient.

The equipment must have one of the following hole patterns (for wall mounting) on its rear panel: 100 x 100; 100 x 200; 200 x 200 or 200 x 400. If this is not the case, a VESA adaptor plate can be obtained from a specialist dealer.

Before installing the receiver it is essential you read the section "Wall mounting" (or the equivalent) in the user instructions for your TV set. This will tell you the screw diameters (M4, M6 or M8) and most importantly the permissible screw penetration depth.



Before starting any installation work, it is essential you disconnect all the units concerned from the mains. If the screws penetrate too deeply into the TV set they may damage it beyond repair and create the risk of a fatal electric shock!



Under no circumstances install the receiver between the TV and a wall support! Installation on the rear panel of a TV set is permissible only if the TV set is resting on a stand that is attached in some other way.

Marking out the screw/drill points at the installation location:

This diagram is to assist you in marking out the exact screw/drill points at the installation location.

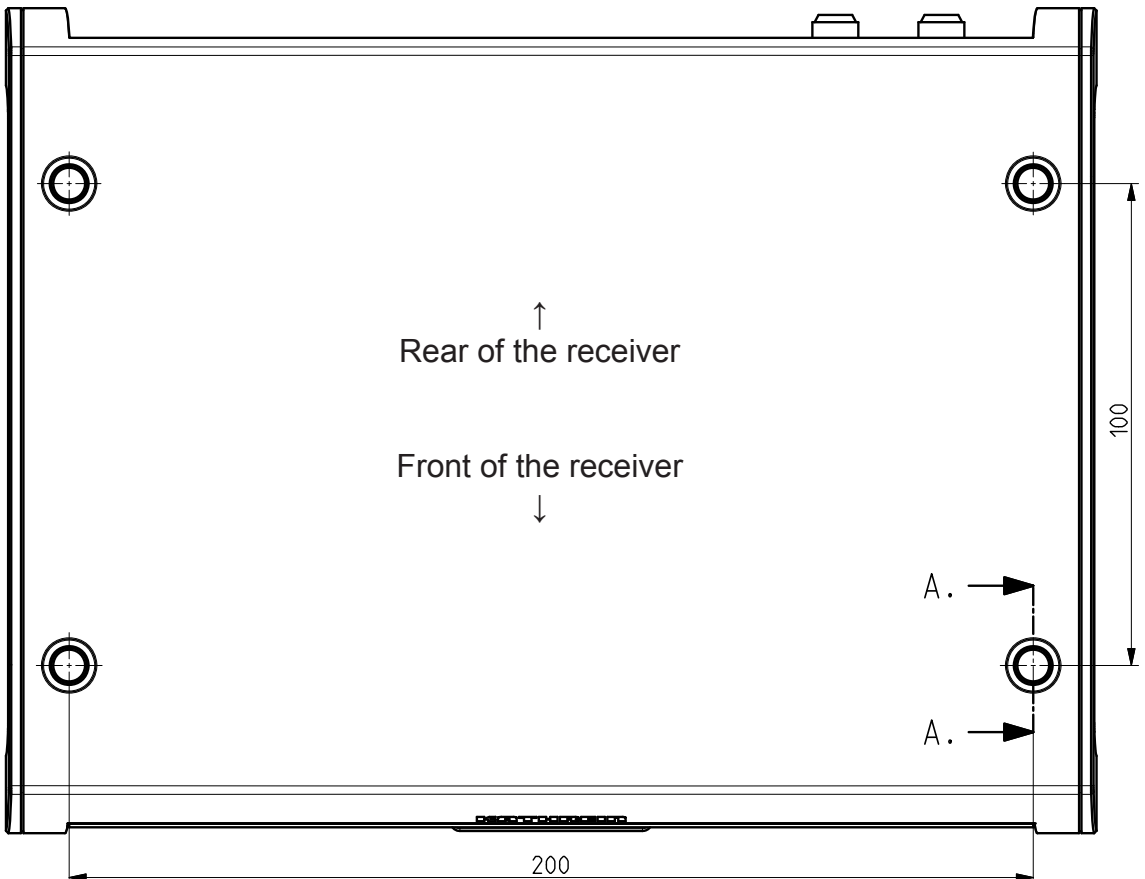

INSTALLATION AND CONNECTION

INSTALLATION

Secure the receiver at the installation location previously selected and prepared.



Do not force it, and take care that not to damage either the screw sockets, the receiver casing itself or any cables that are already attached to the receiver!

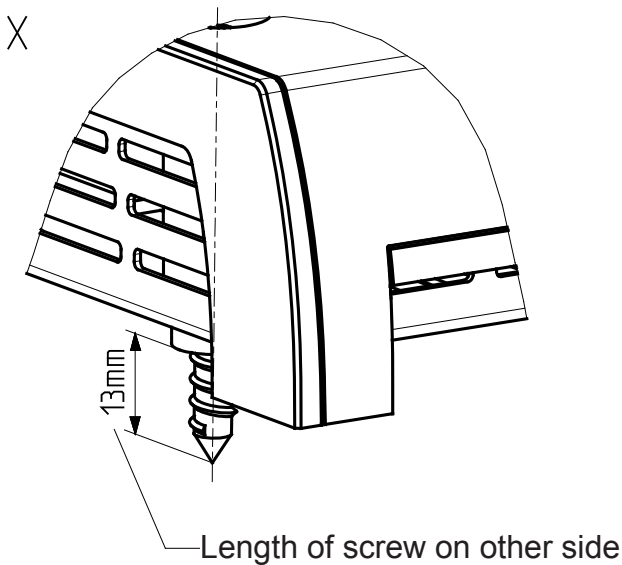
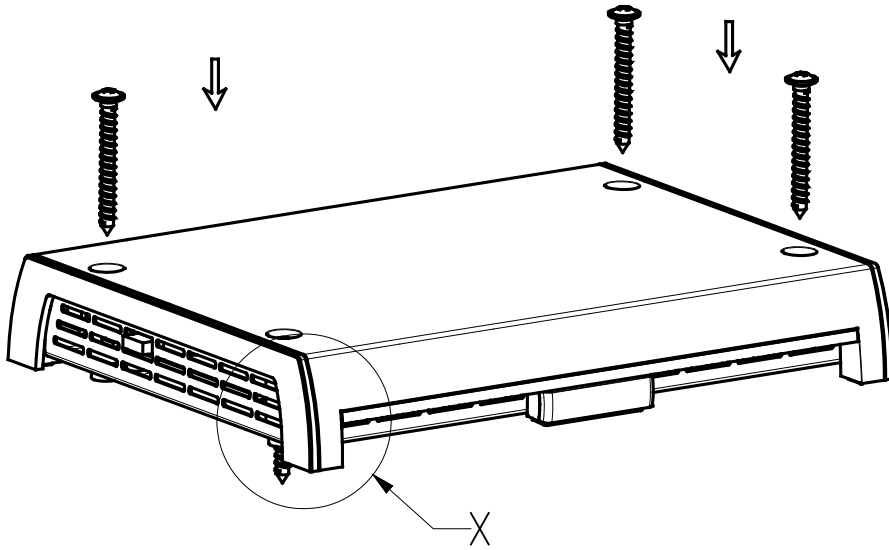

INSTALLATION AND CONNECTION

LAYING CABLES AND CONNECTING THE TURNTABLE

- Lay the master coaxial cable (marked red) to the UFS 940sw and the second coaxial cable to the second receiver. If you are not using a second receiver, we recommend that you lay the second coaxial cable in any case, so that it is available should you ever need it.
- Lay the turntable power supply cable (3-pin plug) to the battery.

Avoid laying the cables across sharp edges and secure the cables against possible chafing points.

- Connect the master coaxial cable (coming from the turntable) to the “IF IN” F socket on the rear of the UFS 940sw.
- Place the infra-red sensor for the receiver close to or directly on top of the TV set and lay the cable to the UFS 940sw. Connect the 6-pin Western connector at the rear to the socket marked “IR REMOTE IN” (see also “Installation of the UFS 940sw receiver” in this section).

Note: *Lay the Cinch cable supplied with the CAP 910. Take great care to plug the cable into the correct socket!*

CONNECTING TO THE UFS 940SW



The receiver must be connected to no other power supply than 12 V DC. The receiver's earth connection must be connected to the negative pole of the motor home or caravan battery.

Isolate the on-board power supply (master switch “off” or disconnect the positive pole of the on-board power supply battery) before commencing the following work:

- Connect the power cable supplied (depending on the power supply available in your motor home or caravan, either a 12 V supply or a 230 V supply via a power supply unit) to the “**12V** **==/2,5A**” plug connector on the receiver.

Make sure that the “inline” integrated fuse (5 A) of the cable is fully plugged in and is intact. If the fuse blows, the source of the fault must first be eliminated. The fuse must only ever be replaced by a fuse with the same rating (5 A).



The fuses in the cable and in the receiver must never be by-passed – cable fire hazard!

- At the connecting point for the power cable, the voltage must not fall below 10.9 V even with a load of 12 A. Otherwise optimum functioning can no longer be guaranteed.
- Connect the power cable to the respective socket in your motor home or caravan (12 V or 230 V).

INSTALLATION AND CONNECTION

Only for connection in a motor home, not in a caravan!

- The third, green connecting cable, marked "IGNITION" allows you the option of connection to a circuit in the vehicle that is activated when the ignition key is turned and then carries a continuous 12 V supply. This type of connection ensures that when the engine is started the antenna is automatically lowered into the park position (the receiver does not need to be turned on).

Note that the antenna can then be lowered only when the power supply is present in addition to the ignition signal!

- Check the connections before you re-connect the on-board power supply.
- For commissioning and more detailed information on additional operator functions, please consult the operation section of the separate operating manual for the receiver.

FUNCTIONAL INSTRUCTIONS FOR CONNECTION TO THE ON-BOARD POWER SUPPLY

Under certain circumstances, problems can arise when the units are connected to different connecting sockets or circuits/earth potentials. If none are available, it is recommended that you connect the connecting sockets for receiver and TV set to the same cable, as depicted in Figure "G". The power rating of the circuit used must be checked with respect to the intended application.

Further information on operating the UFS 940sw receiver can be found in the operating manual supplied with the unit.

INSTALLATION AND CONNECTION

CONNECTION EXAMPLE FOR 12 V BATTERY CONNECTION

Figure: G

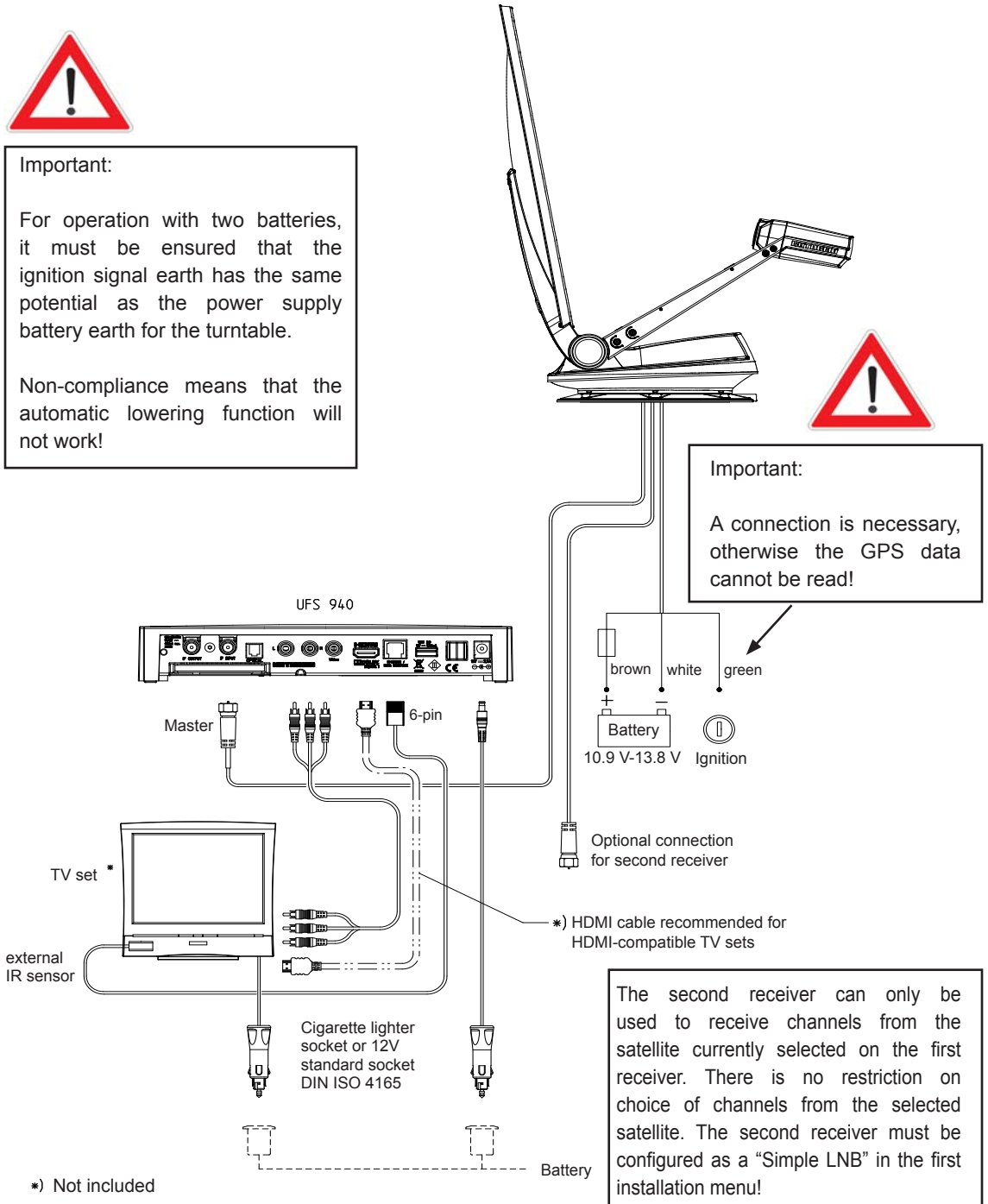

RECEPTION RANGE / FOOTPRINT

The footprint is the reception area on the earth that a satellite covers with its transmission beam (spot), within which satellite reception is possible. The transmission power is at its greatest in the centre of this spot – it becomes progressively weaker moving outwards.

You should preferably align your antenna to the position of the ASTRA satellite 19.2° East (picture below left), EUTELSAT/HOTBIRD 13° East (picture below right). The spots for these satellites are shown below.

The inner line of the footprint here shows the typical reception range for ASTRA with the CAP 910

The outer line of the footprint here shows the typical reception range for EUTELSAT Hotbird with the CAP 910

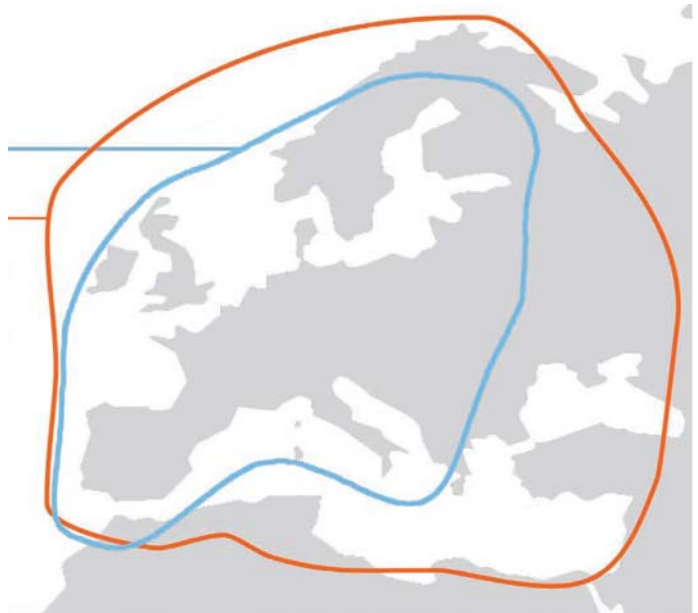

The satellites broadcast the various channel packages in different footprints. The respective channel packages can normally be received within these footprint zones. In the marginal zones, reception is possible, although because of a variety of influencing factors this cannot be guaranteed. The quality of the channels received can vary considerably (for instance due to environmental factors).

DISMANTLING FOR SERVICING

If repairs to the system or individual components are necessary, contact your specialist dealer or our service centre (see below for address).



Never open the turntable yourself!

DISMANTLING



• **Do not cut the cables! Disconnect the cables at the cable disconnection box provided for the purpose!**

- The cables laid within the vehicle can remain there
- Unscrew the six M6 screws securing the turntable to the mounting plate
- Lift the turntable at an angle and insert a suitable piece of wood underneath it
- Disconnect the cables at the cable disconnection box provided for the purpose (remove the plugs)
- Then place the turntable on the prepared wooden supports
- To ship the turntable, use the original packaging which you have saved
- Seal the opening in the vehicle roof appropriately to protect against the ingress of moisture
- If a HDZ 100 roof gland has been fitted and the equipment is then removed, the cable glands no longer used should be sealed with the integral plugs. The enclosure is then watertight once again.

Note: *Before exchanging the UFS 940sw, first move the turntable to the park position.*

ADDRESS OF THE SERVICE CENTRE

Factory repair centre

ESC
Electronic Service Chiemgau GmbH
Bahnhofstraße 108
83224 Grassau GERMANY

Tel: +49 8641 9545-0
Fax: +49 8641 9545-35 and -36
Internet: <http://www.esc-kathrein.de>
e-mail: service@esc-kathrein.de

Regional repair centre

KATHREIN Sachsen GmbH
Lindenstraße 3
09241 Mühlau GERMANY

Tel: +49 3722 6073-31
Fax: +49 3722 6073-18
e-mail: service@kathrein-sachsen.de

MANUAL LOWERING TO PARK POSITION

If a defect arises in the electronic controls, after some disassembly work the antenna can be returned to the park position (horizontal position) manually. Following this however, recalibration by an authorised workshop is always necessary.

Driving to the nearest workshop with the antenna extended at a moderate speed and taking into account the increase (+ 77 cm) in the vehicle height is an option and is preferable to manual lowering!



Users unfamiliar with the necessary repair work are urged not to attempt to lower the antenna manually into park position themselves. They should contact a technician or engineer. They may find a suitable person on the campsite.

In any case, the safety instructions listed below must be followed.

SAFETY INSTRUCTIONS



Make sure that:

- The antenna and connected units are disconnected from the power supply
- The person carrying out the repairs does not suffer from vertigo and can move around safely on the roof of the caravan or motor home
- The person carrying out the repairs is wearing sturdy and non-slip shoes
- The person carrying out the repairs has a secure position to stand and hold on while working

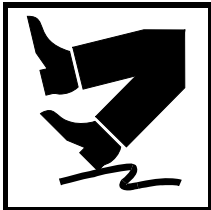

- The roof and the climbing equipment used (e.g. ladder) are dry, clean and non-slip
- The roof can withstand the weight of the person carrying out the repairs

Caution! Risk of death or injury due to falling or roof collapsing!



- Do not hold onto the antenna, as the rocker comes free without warning during dismantling

Caution! Risk of death and injury due to falling or crushing!

- Nobody should be inside the caravan/motor home underneath the antenna during dismantling/installation

Caution! Risk of death or injury due to possible roof collapse and falling parts!

MANUAL LOWERING TO PARK POSITION

MANUAL LOWERING



1. In the centre of the axis (arrowed) there are two plastic caps, one to the left and one to the right. Lever this off with a narrow slot-head screwdriver.
2. Behind this, each jointed socket carries a central M10 cap screw (8 mm across flats); and one of the two sockets carries an additional 2 M6 cap screws (5 mm across flats). Unscrew each of these four screws.
3. Caution! Secure and support the antenna to prevent it tipping over. The connection to the rocker can suddenly come loose during the next step (item 4). It is then no longer connected to the turntable!
4. Screw an M12 screw into each thread (minimum length: 60 mm). Screwing in the M12 screw pushes the rocker off the taper seating on the tapered shaft and releases the engagement.

Important: Screw the screw in only as far as necessary to free the rocker from engagement on the tapered shaft!

5. Tilt the antenna into the park position (horizontal position).
6. Remove the M12 screw.
7. Screw the M10 screws on each side back in again, and also the two M6 screws on the one side, and tighten them.
8. Replace the plastic caps.

Loosening the rocker from the taper shaft causes the rocker zero point position to be lost. The defect must be eliminated and the rocker recalibrated by an authorised dealer!

9. Consult an authorised dealer.



TECHNICAL SPECIFICATIONS

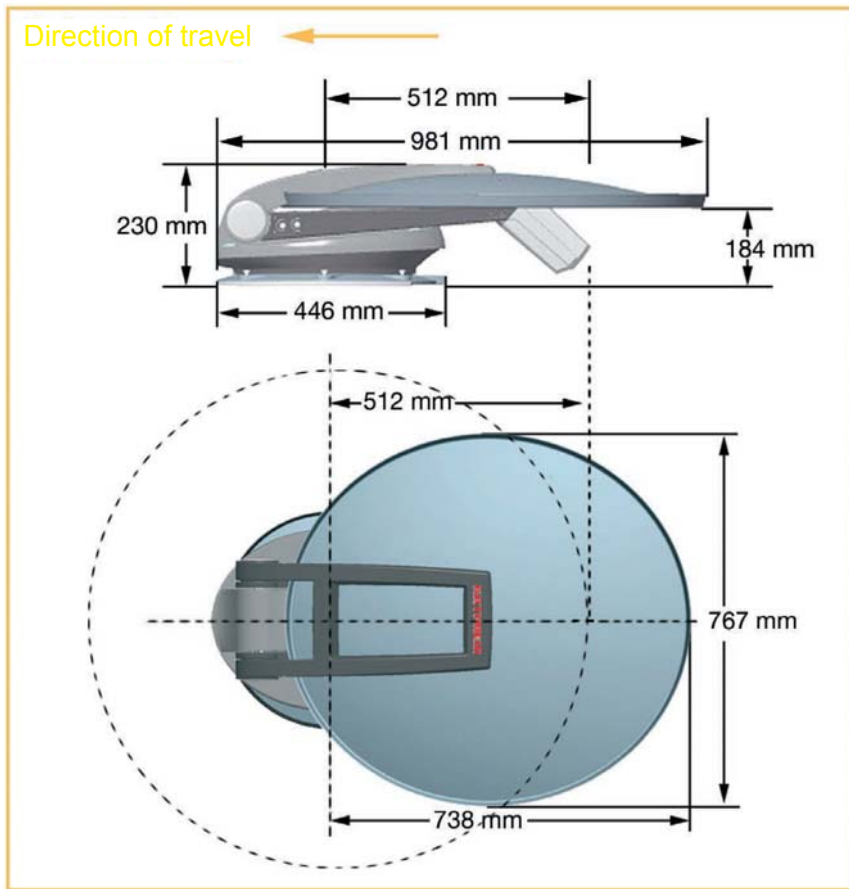

Type		CAP 910
Order no.		20310022
LNB		2 switchable outputs: V/H (14/18 V), low/high (0/22 kHz)
LNB supply voltage	V	vertical: 11.5-14, horizontal: 16-19
Input frequency	GHz	10.70-12.75
Output frequency	MHz	950-1950/1100-2150
Oscillator frequency (L.O.)	GHz	9.75/10.60
System quality (G/T) 11.3/12.5 GHz	dB/K	16.9/17.9
Power supply (vehicle battery)	V	10.9-13.8
Power consumption from the 12 V vehicle electrical system: Inrush current/satellite search/TV-reception/stand-by	A	Type 10, max. 12/type 3/type 1.2/type 0.024
Current consumption from the receiver	mA	Type 200
Setting range: Elevation/azimuth/skew	°	3-67/390± 45
Weight (without receiver)	kg	18.9
Packing unit/weight	Units/kg	1/22

SIKAFLEX[®] 291 SAFETY DATA SHEET

1. Materials/preparation and company designation

Data on the product (trade name): Sikaflex[®] 291
Data on manufacturer/suppliers
Manufacturer/suppliers: Sika Deutschland GmbH
Street/postcode: Kornwestheimer Str. 103-107
Postcode and town: Stuttgart
Country: Germany
Tel: +49 711 80090 Fax: +49 711 8009321
General information: Product safety
Emergency information hotline: +49 173 6774799 only outside office hours

2. Composition/data on components

Chemical characterisation: Filled reactive PUR polymer

Hazardous contents (designation to 67/548/EEC)

CAS-No.	Concentration	Danger symbols	R phrases	EC no.
Naphtha (crude oil), hydro-desulphurised heavy 64742-82-1	1 - 2.5 %	Xn,N	10,65,51/53,66,67	265-185-4
4,4' methylene-diphenyl-diisocyanate 101-68-8	0.1 - 1 %	Xn	20,36/37/38,42/43	202-966-0
Xylol 1330-20-7	1 - 2.5 %	Xn	10,20/21,38	215-535-7

3. Potential hazards

Hazard designation:

Xn Hazardous to health

Special hazard instructions for human beings and the environment

42 Sensitisation possible by breathing in.

4. First Aid measures

General instructions

In all cases show the doctor the safety data sheet.

After breathing in

In the event of trouble consult a doctor.

After contact with the skin

After contact, wash the skin with soap and water.

In the event of continuing skin irritation consult a doctor.

After contact with the eyes

In case of contact with the eyes, wash with copious water for 15 minutes.

Summon a doctor immediately.

After swallowing

Do not induce vomiting. Summon a doctor immediately.

SIKAFLEX[®] 291 SAFETY DATA SHEET

5. Measures for fire fighting

Suitable extinguishing media

Compatible with all extinguishing media in general use.

Special hazard from the product, its products of combustion or gases released

In case of fire the following can be released: Carbon monoxide (CO)

Carbon dioxide (CO₂)

Hydrogen chloride (HCl)

Oxides of nitrogen (NO_x)

Additional instructions

Combustion residues and contaminated extinguishing media must be disposed of in accordance with the local authority regulations. Collect contaminated extinguishing water separately, do not allow it to run into the drains.

6. Measures if inadvertently released

Personal precautions

Ensure sufficient ventilation.

Wear protective clothing.

Where vapours/dust/aerosols are present, wear a breathing mask.

Environmental protection measures

Do not allow to run into the drains or bodies of water.

In the event of penetration into water, ground or drains, inform the responsible authorities!

Procedure for cleaning/clearing up

Absorb with media that bind to liquids (e.g. sand, sawdust, universal binding media).

Dispose of the material that has been cleared up in accordance with the section on Disposal.

7. Handling and storage

Handling

Instructions for safe handling:

Refer to Section 8 / Personal protective equipment.

Instructions for fire and explosion prevention: Not applicable

Storage

Requirements for storerooms and containers:

Containers should be dry, kept tightly sealed and stored in a cool, well ventilated place.

Storage proximity instructions

Store separately from all kinds of foodstuffs.

Additional instructions for storage

Protect against frost.

Protect against heat and direct sunlight.

Protect against atmospheric humidity and water.

* 8. Exposure limitation and personal protective equipment

Components subject to monitoring of workplace concentration limits

Designation of the component

CAS no. type

Reference/country/year

Naphtha (crude oil), hydro-desulphurised heavy

64742-82-1 Permissible workplace concentration 350 mg/m³

TRGS 900/DE/2004

64742-82-1 Permissible workplace concentration 70 ml/m³

TRGS 900/DE/2004

SIKAFLEX[®] 291 SAFETY DATA SHEET

4.4' methylene-diphenyl-diisocyanate

101-68-8	Permissible workplace concentration	0.05 mg/m ³	TRGS 900/DE/2004
101-68-8	Permissible workplace concentration	0.005 ml/m ³	TRGS 900/DE/2004

Xylol

1330-20-7	Permissible workplace concentration	440 mg/m ³	TRGS 900/DE/2004
1330-20-7	Permissible workplace concentration	100 ml/m ³	TRGS 900/DE/2004
1330-20-7	EU-TWA (8h)	221 mg/m ³	2000/39/EC
1330-20-7	EU-TWA (8h)	50 ml/m ³	2000/39/EC
1330-20-7	EU-STEL (15')	442 mg/m ³	2000/39/EC
1330-20-7	EU-STEL (15')	100 ml/m ³	2000/39/EC

Personal protective equipment

General protective and hygiene measures

Ensure sufficient ventilation at the workplace.

Avoid contact with the eyes and skin.

Apply prophylactic skin protection by protective hand cream.

Take off soiled clothing immediately.

Do not smoke, eat or drink when handling the product.

Before breaks and after completing work, wash hands well.

Breathing protection

When ventilation is poor: ABEK multi-range filter

The gas filter class is dependent on the local concentration of injurious substances.

Hand protection

Wear butyl rubber/nitrile rubber gloves

Eye protection

Safety glasses

Body protection

Work clothing

* 9. Physical and chemical characteristics

Appearance

Form:	pasty
Colour:	various, depends on the pigment
Smell:	characteristic

Safety-relevant data, methods

Flashpoint:	> 65 °C
Density at 20°C:	approx. 1.26 g/cm ³
Solubility in water:	reacts with water
Viscosity at 20°C:	not applicable
VOC (solvents):	3.47 %
VOC (CH):	3.47 %

10. Stability and reactivity

Substances to be avoided/hazardous reactions

No hazardous reactions if correctly stored and handled.

Thermal decomposition and hazardous products of decomposition

No decomposition if used correctly.

SIKAFLEX[®] 291 SAFETY DATA SHEET

11. Toxicology data

Sensitisation

Sensitisation/allergic reactions may occur.

Sensitive individuals may exhibit allergic reactions even at very low concentrations.

Experience of human exposure

On skin contact: May lead to irritation

On eye contact: May lead to irritation

On being breathed in: May lead to irritation

On being swallowed: May lead to health problems

12. Ecological data

Additional instructions

Do not allow to run into the drains, bodies of water or the ground.

13. Disposal instructions

Product

Recommendations

In accordance with the applicable waste labelling regulations, waste should be classified by its origin. Therefore a unique waste code number cannot be assigned.

Packaging

Recommendations

Packaging that is empty of residues should be sent for recycling. Packaging that contains residues of hazardous substances or which is contaminated with hazardous substances, and any packaging that is not empty of residues should be disposed of as the product, correctly and without creating pollution.

If the last contents makes it necessary, packaging that is empty of residues must be pre-treated for disposal (e.g. washed out, neutralised, cured, shaken out).

14. Transport data

ADR/RID

Further data

Not hazardous cargo.

IMO/IMDG

Marine pollutant: no

Further data

Not hazardous cargo.

IATA/ICAO

Further data

Not hazardous cargo.

15. Regulations

Identification in accordance with EC directives

The product should be classified and identified in accordance with EC directives/national statute law.

Component(s) to be labelled as hazardous content: 4.4' methylene-diphenyl-diisocyanate

Hazard symbols

Xn Hazardous to health

SIKAFLEX[®] 291 SAFETY DATA SHEET

Risk phrases

42 Sensitisation possible by breathing in.

Safety phrases

23 Do not breathe in gas/smoke/vapour/aerosol.

45 In the event of accident or feeling unwell summon a doctor immediately (if possible show the doctor this label).

Special identification of particular components

Contains isocyanates. Follow the manufacturer's instructions.

National regulations

Water contamination class

WGK 1 (to VwVws of 17. May 1999)

GISCODE/PRODUCT CODE

GISCODE : PU 50

16. Other data

Markings (*) in the left margin indicate revisions from the previous version.

Intended purpose: Chemical product for building and industry

Risk phrases for the constituent substances listed in Section 2

10 Flammable.

20 Hazardous to health if breathed in.

20/21 Hazardous to health if breathed in and if comes in contact with the skin.

36/37/38 Irritates the eyes, breathing organs and the skin.

38 Irritates the skin.

42/43 Sensitisation possible by breathing in and by contact with the skin.

51/53 Poisonous to water organisms, can have long-term polluting effects on bodies of water.

65 Hazardous to health: can cause damage to lungs if swallowed.

66 Repeated contact can lead to brittle or cracked skin.

67 Vapours can cause drowsiness and light-headedness.

The data in this safety data sheet represent our knowledge at the time of publication. They are not warranted as a complete list of characteristics. The only warranty extended is that expressed in the technical data sheets and the general conditions of sale. Consult the technical data sheet before use.

SIKAFLEX® 291 TECHNICAL DATA SHEET

Technical data sheet
Version 12/2005

Sikaflex®-291

The strongly bonding marine adhesive

Technical characteristics

Chemical basis	1-component polyurethane	
Colour	white, black, natural wood	
Curing mechanism	cures by absorbing moisture	
Density before curing (DIN 53479)	approx. 1.3 kg/l, depending on colour	
Stability	good	
Processing temperature	+5°C - +40°C	
Skin formation time ¹	60 min.	
Through-curing speed	(see digiagram 1)	
Volume change (DIN 52451)	approx. -5%	
Shore A hardness (ISO 868 / DIN 53505)	approx. 40	
Tensile strength (ISO 527 / DIN 53504)	1.8 N/mm ²	
Elongation at break (ISO 527 / DIN 53504)	approx. 400%	
Tear propagation resistance (ISO 34 / DIN 53515)	approx. 6 N/mm	
Glass transition temperature (ISO 4663 / DIN 53445)	approx. -45°C	
Operating temperature short-term	sustained	-40°C to +90°C
	4 hours	160°C
	1 hour	180°C
Storage life (storage at less than 25°C in unopened containers)	12 months	

¹ 23°C / 50% r.Lf.

Industry

Description

Sikaflex® 291 is a stable 1-component polyurethane sealant developed for boatbuilding and shipbuilding. On exposure to atmospheric moisture it reacts to become an elastomer. Sikaflex® 291 satisfied the requirements of the International Maritime Organisation (IMO). Sikaflex® 291 is manufactured in accordance with the ISO 9001/14001 Quality Assurance System and the Responsible Care Programme.

Product advantages

- 1-component
- flexible
- low odour
- resistant to ageing and weather
- non-corrosive
- can be painted over
- can be sanded
- broad bonding spectrum
- electrically non-conductive
- resistant to seawater and hydrolysis

Application Range

Sikaflex® 291 is a versatile product for use in boatbuilding and shipbuilding to make flexible and vibration-resistant seals in internal and external areas. Sikaflex® 291 has strong bonding properties to the principal materials used in shipbuilding. Suitable substrates include wood, metals, primers and paint finishes (2-component system), ceramic materials, plastics (UP-GFK etc.). Sikaflex® 291 should not be used for sealing plastics that are subject to stress cracking (such as PMMA, PC etc.).

For timber decking we recommend Sikaflex® 290 DC. In the cured condition, Sikaflex® 291 can be sanded without problems.

Curing mechanism



SIKAFLEX® 291 TECHNICAL DATA SHEET

The cross-linking reaction of Sikaflex® 291 occurs in the presence of atmospheric moisture. At lower temperatures the water content of the air is less and the cross-linking reaction proceeds somewhat more slowly (see diagram).

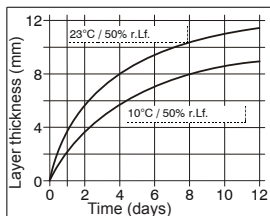

Diagram 1: Through curing speed of Sikaflex® 291

Chemical Stability

Sikaflex® 291 is resistant to fresh water and salt water, hard water and effluent from public drains including aqueous surfactants, dilute alkalis and acids; short-term resistant to fuels, mineral oils including vegetable and animal oils and greases, not resistant to organic acids, alcohol, stronger mineral acids and alkalis or solvents. This information is intended only as a general indication. Advice for specific applications is available on request.

Processing instructions

Substrate preparation

The surfaces to be bonded must be clean, dry, and free of dust and grease. Data on preparation of materials surfaces can be found in the primer table for Sikaflex® marine systems.

Processing

Break the cartridge membrane and fully open it. Insert the bag into the application gun and cut off the clip. Cut off the tip of the nozzle to suit the crack to be filled, and apply the sealant with a suitable manual, battery-powered or compressed air piston gun into the crack, leaving no air bubbles. Opened containers must be used up within a few days. The processing temperature must not be below 5°C or above 40°C. The optimum temperature both material and sealant is between 15°C and 25°C.

For advice on selection and arrangement of a suitable pump system, please contact the System Engineering Department at Sika Industry.

Smoothing off

Smoothing off must be performed within the skin formation time of the adhesive. We recommend Sika® N smoothing off agent. Other smoothing off agents should be checked for suitability before use.

Removal

Uncured Sikaflex® 291 can be removed from equipment and tools with Sika® Remover 208. Cured material can only be removed mechanically. Hands/skin should be cleaned immediately with Sika® Handclean or a suitable hand cleansing paste and water. Do not use solvents!

Painting over

After the skin has formed, Sikaflex® 291 can be painted over. The suitability for painting over must be trialled prior to application. Powder coating points may be applied only to fully cured Sikaflex® 291. It should be borne in mind that the hardness and film thickness of the paint finish may affect the expansion of the plastic and lead to cracking.

Additional information

The following documents are available on request:

- Safety data sheet
- Primer table for Sika marine systems
- General guidelines for working with Sikaflex® adhesives and sealants
- Marine handbook

Containers

Tube	100 ml
Cartridge	310 ml
Bag	400 ml

Important

When handling our products, please read the material-specific safety data sheets for their essential physical, safety, toxicological and ecological data. The applicable regulations, such as the hazardous substances regulations should be complied with. On request we will send you our system data sheet TM 7510 "Instructions for protection at work" for handling Sika Deutschland GmbH products.

Note:

The details above, especially the suggestions for the processing and use of our products are based on our knowledge and experience in normal cases, providing the products are correctly stored and applied. Due to the variety of materials, surfaces and variations in working conditions, no guarantee of a work product or liability from any legal relationship can be founded on these instructions or on oral advice unless we are charged with premeditated or gross negligence. Here the user must prove that he brought to Sika's attention promptly, completely and in writing all knowledge necessary for Sika to make an objective assessment of expectation of success. It is the user's responsibility to check the products for suitability for the intended application. We reserve the right to change the product specifications. The trademark rights of third parties must be respected. In all other respects our respective sales and delivery conditions apply. The latest version of the technical data sheet is applicable and should be requested from us.

Additional information
Internet: www.sika-industry.de, e-mail: industry@de.sika.com
www.sika.com

Sika Deutschland GmbH
Kleb- und Dichtstoffe Industrie
Stuttgarter Strasse 139
D-72574 Bad Urach
Germany
Tel. +49 7125 940-761
Fax +49 7125 940-763



Sikaflex® 291 2 / 2

The operating manual for the

CAP 910

If, despite studying this operating manual, you still have questions about getting started with the unit or using it correctly, or if unexpected problems occur, please contact your specialist dealer.

The Kathrein Technical Customer Support is also at your disposal. Tel: +49 8031 184-700



The automatic overnight updating of the EPG data described in the UFS 940sw operating manual is not performed automatically when the UFS 940sw is being operated on the CAP 910! The EPG data are updated when an individual channel is viewed. At this point however the receiver updates all EPG data for the channels that are broadcast from the currently selected receiving transponder.

For example: You have selected the channel "SAT.1". At this point for instance the EPG data will be updated for "ProSieben" and "KABEL1".

IMPORTANT INFORMATION FOR CAP 910 BEFORE SETUP



This section of the UFS 940sw operating manual for the turntable assumes that the UFS 940sw and the turntable have been properly installed and connected, as described in the installation and operating manuals.

If you have not yet done so, read the safety instructions at the beginning of the UFS 940sw operating manual and follow them when handling the UFS 940sw and the turntable unit.



Before setting up your satellite system, make sure that the location allows a free view to the satellite positions to the South and is not shadowed by trees or other obstructions. This will save you time and effort.



So as to avoid overheating the turntable motors, do not operate the motors continuously for longer than 20 minutes.

None of the search procedures initiated by the CAP 910 will require as much as 20 minutes operation. Only repeated unsuccessful search procedures or manual overrides by the user can cause this limit to be exceeded.



As soon as the ignition signal is no longer present at the turntable, if the receiver is switched on the turntable will be supplied with a +12 V power supply and may automatically move to the last known satellite position. Therefore switch your receiver on only if you wish to use your CAP 910.

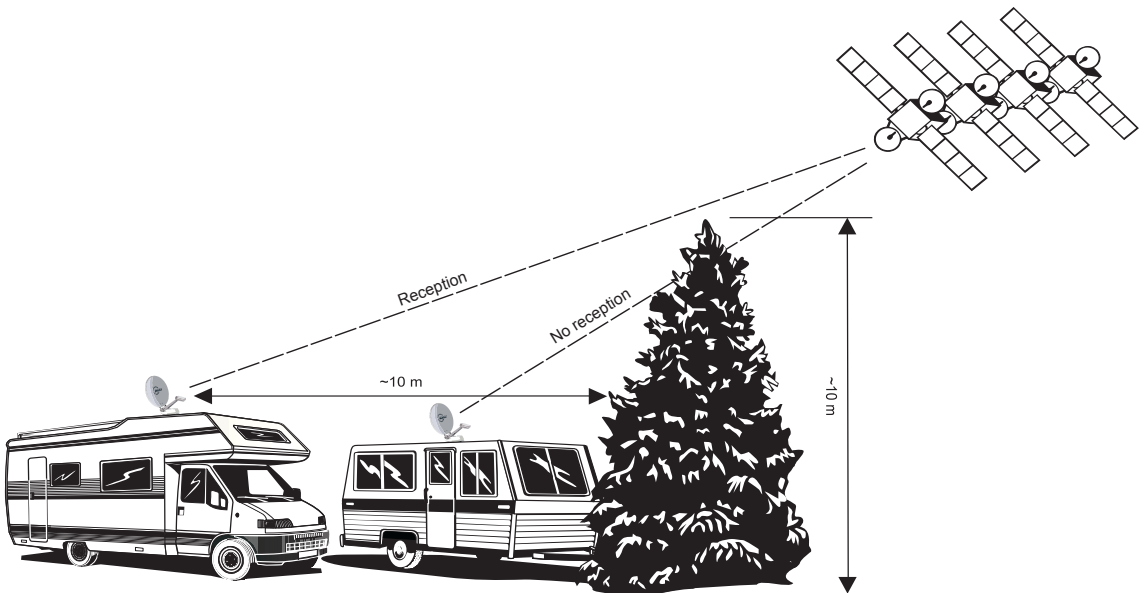

REMOTE CONTROL

All settings on the UFS 940 are made using the remote!

FIRST INSTALLATION

Before using your unit for the first time, read the “Safety Instructions - Important Information” and “Installation and Connection” sections.

You will find a sample configuration for a motor home in the Section “Installation and connection”, “Connection Example”.



Do not connect the unit to the power supply until all installation work has been properly carried out.

The guidance given in the “First Installation” section assumes that the receiver has been properly connected, as per the “Safety Instructions - Important Information” and “Installation and Connection” sections.

First switch your TV set on and select the AV or video/HDMI channel number to which you have connected the receiver. Switch on your receiver at the power switch on the rear of the unit. The following display appears:



Also note the bars at the bottom of the on-screen display! These provide information on what to do next.

Select the menu language you want using the   buttons. Available options: German, English, French, Italian, Spanish, Czech, Dutch, Polish, Norwegian, Turkish and Russian.

Press the  (green) button to move to the next menu.

Note: *If you are unsure whether you chose the right option from a previous menu, you can go back a step at any time during the first installation process by pressing the  (red) button.*

FIRST INSTALLATION

The following display appears:

Use the  buttons to select whether to replace the factory pre-programmed channel list by a pre-sorted channel list for a specific country (at present only a limited number of pre-sorted channel lists are available). If you prefer to use the factory pre-programmed channel list, choose “No” under “Restore Channellist”.



Press the  (green) button to move to the next menu.

The following display appears:

Use the  buttons here to select the basic settings for the video and audio output from the receiver to the TV set.

For this, refer to the operating manual for your TV set and take care to select only those settings that your TV set can process.



Video Output via

Select the connection on the receiver to which you have connected your television.
Either

HDMI



or

VIDEO



Note: *The better picture quality, in particular for HDTV signal is obtained via the HDMI port. The precondition for this however is that your TV set has a HDMI port.*

HDMI Format

Here you can select the picture resolution that will be sent to your TV set. Either

- 1080i (resolution 1920 x 1080, half-screen images)
- 576p (resolution 720 x 576, full-screen images) or
- 720p (resolution 1280 x 720, full-screen images)
- automatically

TV Format

Here you can select the TV picture format. Either

- 4:3 or
- 16:9

FIRST INSTALLATION

Show 4:3 event

Here you can select the type of screen display mode for 4:3 broadcasts on a 16:9 TV set:

- normal (pillarbox)
- Stretched (Full Screen) or
- zoom in (Pan & Scan)

Audio format via HDMI

Here you can select the type of audio signal that is transmitted by the HDMI interface. Select the signal that your TV set can process:

- Decoded PCM or
- S/PDIF format

TV standby via HDMI

If you select "Off", the TV set must be switched on or off separately. If you select "On", the TV set will be switched on automatically as the receiver starts up (but only if the TV set was in stand-by mode). If the receiver is switched off into stand-by mode, the TV set will also be switched to stand-by mode.





Automatically switching the TV set on/off by the receiver is available only if the TV set supports this function!

Press the  (green) button to move to the next menu.

The following display appears:





System

Use the   buttons here at "System" to select "CAP". Then use the   buttons to select the "Initialize CAP" line and press the  button to confirm.

FIRST INSTALLATION

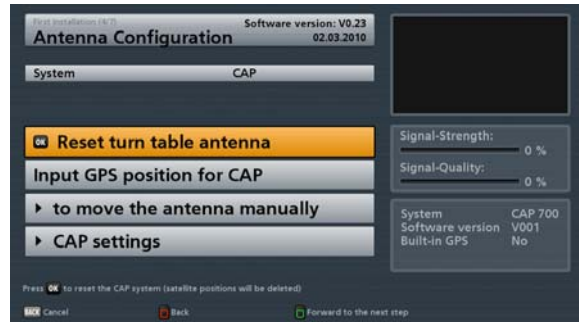

Your CAP system will then be initialised. You will then see the following display:



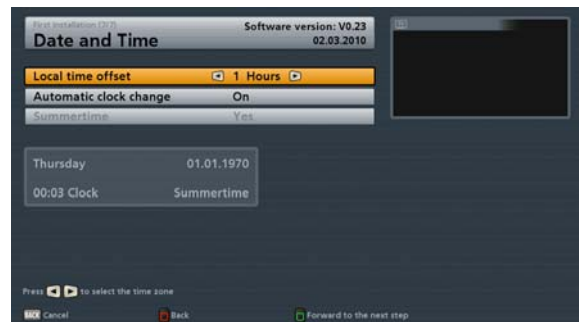

Press the  (green) button to move to the next menu. The following display appears:



Local time offset (UTC)

Here you can use the   buttons to select the local time offset to UTC (formerly GMT) (e.g. for Germany: + 1 hour). You can set the offset in 1 hour steps. The maximum offset is 12 hours (+ and -).

Automatic clock change (summer/winter time)

Use the   buttons to select whether the receiver should automatically change over to and from summer and winter time. If "On" is selected, the receiver automatically sets itself to the right time. If you select the setting "Off", you must make the change to and from summer time manually by setting the "Summertime" field to "Yes" or "No".

When you have completed all settings, press the  (green) button, to complete the first installation.

CAP MENU (TURNTABLE ANTENNA SETTINGS)

CALLING UP THE CAP MENU

Press the  (green) button. The following display appears:

Use the   buttons to select the “Antenna Configuration” line and press

the  button to confirm.

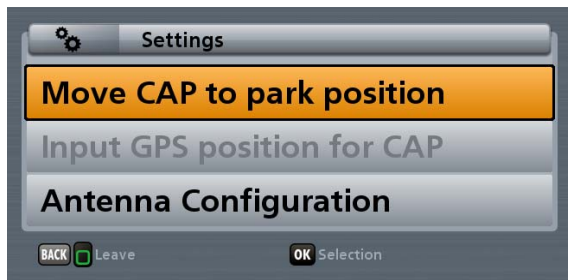

The following display appears:

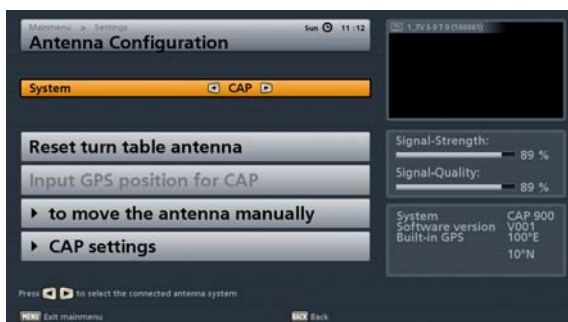

You can also call up this menu via the main menu “Settings”, “Antenna Configuration” (System: CAP).





RESETTING THE CAP SYSTEM (TURNTABLE ANTENNA) (RESET)

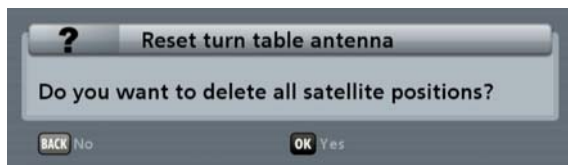

All satellite positions found by a search will be deleted.

Use the   buttons to select the “Reset turn table antenna” line and press the  button to confirm. The following display appears:



Press the  button to confirm, or the  button to cancel.

Note: Before exchanging any component of the system (such as the receiver) the turntable should be moved to its park position by means of the “Reset turn table antenna” command. The “Reset” deletes all previously saved satellite positions. The satellite data in the UFS 940sw receiver are however retained.

CAP MENU (TURNTABLE ANTENNA SETTINGS)

INPUTTING THE CAP GPS POSITION

Function not available with the CAP 910 as the GPS data is automatically provided during your journey.

Note: *To help ensure the required satellite is found quickly, the CAP 910 uses GPS data recorded during the journey. However, GPS data is only recorded if both the green ignition lead and the turntable are connected to the 12 V power supply (the receiver can remain switched off). If this is not possible, we recommend that you connect the turntable and the ignition signal to the 12 V power supply for approximately 3 minutes before setting up the system. The current GPS data will be provided during this time. Once the ignition signal has been removed, the receiver can be switched on. The CAP 910 now searches for satellites using the exact elevation.*

TO MOVE THE ANTENNA MANUALLY



This function should be used only by experienced users. Exact knowledge of the satellite position and your present location are necessary when aligning the antenna manually to a satellite. Watch out for any obstacles that the antenna might collide with. The antenna is liable to be damaged by such collisions!

You can set the inclination and horizontal angle of the antenna using the “Elevation” and “Move to the azimuth (rotate the antenna)” commands. Check your settings by referring to the “Signal-Strength” and “Signal-Quality” bars on the right-hand side. The higher the bar, the stronger and better quality the signal received.

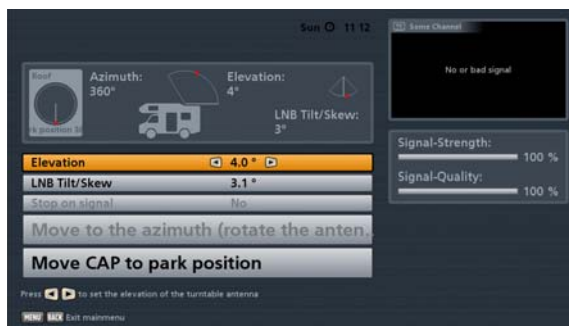

The currently displayed position of the CAP is the “park position”.



ELEVATION

Using the numeric keys and/or the   buttons, input the desired elevation value.



Two seconds after completion of the input or when the  button is pressed, the CAP moves to the selected position.

CAP MENU (TURNTABLE ANTENNA SETTINGS)

LNB TILT/SKEW

Using the   buttons or the numeric keys, enter the required tilt angle (skew) for the LNB and press the  button to confirm. Check your settings by referring to the “Signal-Strength” and “Signal-Quality” bars on the right-hand side. The higher the bar, the stronger and better quality the signal received.

STOP ON SIGNAL





Use the   buttons to select whether the CAP should stop automatically (Yes or No) on detection of a satellite signal during manual alignment by the user.

MOVE TO THE AZIMUTH (ROTATE THE ANTENNA)

As soon as you switch the orange bar to the “Move to the azimuth (rotate the antenna)” line you will see the following display:



You now have the following options for rotating your CAP:

- “Step by step” using the   buttons
- “Move towards min” (minimum rotary position) with the  button or
- “Move towards max” (maximum rotary position) with the  button

Note: *If you previously set “Stop on signal” to “Yes”, the antenna will stop as soon as it detects a satellite signal.*

CAP MENU (TURNTABLE ANTENNA SETTINGS)

MOVE CAP TO PARK POSITION

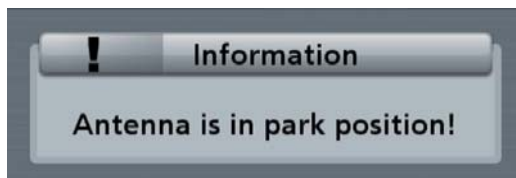

Press the  button; the CAP will move to the park position. As soon as the turntable reaches the park position, the following display appears:



CAP SETTINGS



This menu allows important basic settings for the CAP, such as the elevation border or elevation offset to be set. These two settings in particular should be performed by a specialist to match your needs and the conditions; if they are set incorrectly the CAP may be damaged!

Use the   buttons to select the “CAP settings” line and press the  button to confirm. The following display appears:





ELEVATION BORDER AND ELEVATION OFFSET

Neither of these settings should be changed unless the change is necessary because of neighbouring roof structures or other obstacles. The settings are made using the cursor buttons  or the numeric keys.

SEARCH SPEED

In the fringe areas of the satellite footprints it may happen that a better search result is obtained by using a lower CAP search speed. If the “Regular” search speed does not give satisfactory search results, you can reduce the search speed to “Slow”.



If the signal strength and quality are good however you can set search speed to “Quick”. Normally we recommend the search speed is set to “Regular”.

Make the settings using the   buttons.

CAP MENU (TURNTABLE ANTENNA SETTINGS)

COUNTDOWN FOR THE SEARCH START

Set the “Countdown for search start” on the display shown to the right. Use the

  buttons to set the countdown. You can set the countdown to between one and ten seconds in one-second increments or alternatively select “Off”. If you select “Off”, the CAP starts searching for satellites immediately.

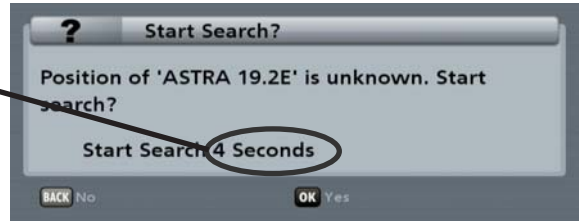

RESTORE FACTORY SETTINGS

If you select the “Restore factory settings”

option and press the  button to confirm, all your settings within the “Antenna Configuration” menu will be reset to the factory setting. However, in contrast to the “Reset turn table antenna” command, all other settings will be retained, along with satellite positions that have already been detected and saved.



ALIGNMENT (SATELLITE SEARCH)

The antenna is aligned automatically. After the UFS 940sw has been switched on, the turntable automatically moves to the last channel received and the associated satellite position (e.g. ARD/ASTRA). This works because each satellite is automatically recognised by the turntable.

The satellite search is started when you select a channel. If the turntable has not yet saved the position of the satellite, you will see the following display when you select a channel (example):



If the vehicle is not on supports during the search process and people are moving around inside it, there is a risk that movement of the vehicle will mean that the satellite is not found.

You will see this display if the CAP has not yet saved a satellite position (e.g. after the CAP has been reset or during the First Installation).

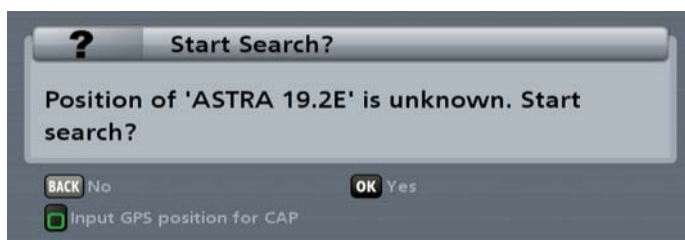

You will see this display if the CAP has already saved a satellite position but because for instance the location of the vehicle has changed, the satellite is no longer to be found at the know/saved position.

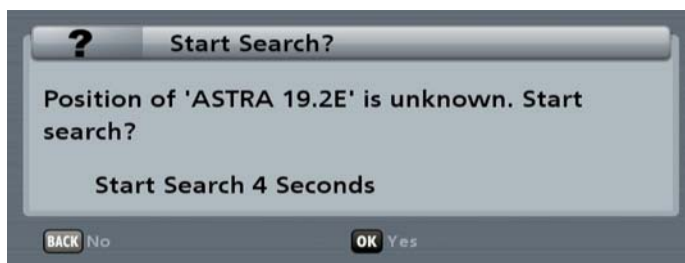

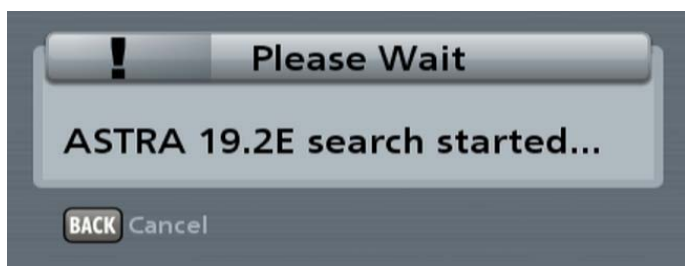

The search starts automatically after five seconds or if the button was pressed previously. The search may take a few minutes (generally about two minutes). You will first see the following message:



As soon as the turntable has found the correct satellite, it saves this position. During this process you receive no TV picture. The turntable will then perform an automatic fine adjustment (if the signal level is sufficient, the satellite position will be saved immediately by the turntable). During the fine adjustment you will for the first time receive a TV picture, this however can still “freeze” during the fine adjustment process - whether it does or not is system-dependent.

The set position (of the satellite that was found) is saved and the desired channel appears on the TV screen.

CHANNEL (SATELLITE) SELECTION/PROGRAMMING THE TIMER

By pressing the  buttons all channels can be selected in the sequence that they appear in the current channel list and its sorting. Press the  (blue) button to switch between TV and radio channels.

CHANNEL SELECTION FROM THE CHANNEL LIST

Providing you are not in a menu, pressing the  button calls up the channel list. The following display appears:





The screenshot shows the 'TV Channel Complete List' interface. The list includes channels like 'Das Erste HD', 'ZDF HD', 'SAT.1', 'RTL Television', 'RTL2', 'VOX', 'ProSieben', 'kabel eins', 'Bayerisches FS Süd', 'BR-alpha', 'WDR Köln', and 'NDR FS NDS'. The right side of the screen displays signal strength and quality information for the selected channel, including 'ASTRA 19.2E DVB-S2', '11361 MHz', 'Horizontal', and '22.000 MS/s'. At the bottom, there are buttons for 'Select List', 'Select Satellite', 'Alphabetically', and 'TV / Radio'.

Call up the complete list
 (green button)

Channel list

Call up the favourites lists
 (red button)

Call up sorting by satellites, new channels and last search

Call up alphabetic sorting
 (yellow button)

Call up the search function
 button) can be called up from any channel list

Channel data:
 - Transmitting satellite
 - Transponder frequency
 - Polarization
 - Symbol rate

Signal strength and quality

Switching between the TV/Radio lists



Currently selected channel list

Currently selected channel



Live picture from the selected channel

When you open this list the channel list selection/sort order is displayed from where you selected the last channel.

For instance you can use the  buttons to display various channel lists sorted by satellite (e.g. ASTRA 19.2° or Hotbird 13°).



The cursor buttons  are used to navigate within the respective channel list view to select the desired channel. The selection of the desired channel is confirmed by pressing the  button. As soon as the turntable has found the satellite or has reached the known position, you will now hear and



CHANNEL (SATELLITE) SELECTION/PROGRAMMING THE TIMER

view the currently selected channel in the small window at the top right. To exit the channel list and return to the TV picture, press the  button again, or press the  button.

Note: *A comprehensive explanation of the channel list with its detailed functions (e.g. the scan and sort function) can be found in the UFS 940sw operating manual.*

CHANNEL SELECTION FROM THE CHANNEL LIST (SORTED BY SATELLITE)

To view the channel list sorted by the saved satellites, proceed as follows. Press the  button (starting from the TV picture). If the “green view” does not appear in the complete list, press the  (green) button.

Now use the   buttons to select the desired satellite. You will automatically see the channel list stored for the satellite (see example):



The channel selection functions as previously described “Channel selection from a channel list”.

TIMER PROGRAMMING

The timer function is currently not yet available in CAP mode!

See the UFS 940sw operating manual for details of how to program the timer. When using the UFS 940sw on a CAP 910 please note the following additional instruction:



To prevent the turntable rotating at a time when it is unsupervised or when rotation might be irritating (e.g. in the middle of the night), a timer can be set. During the timer period the turntable is active only if the UFS 940sw is in operation or is in standby mode.

If the receiver is completely switched off (switched off at the power socket) and/or the turntable is in park position, the turntable will be inactive during the timer period! The same applies if during the first movement the satellite position is not found.

CHANGE OF LOCATION

After a change of location, the antenna moves to the last position selected. After initialisation, you will therefore see the following display (example, as it depends on the last selected position):

For slight changes of location, the antenna can find the satellite very quickly.



If the satellite is not found at the known position, the search starts automatically.

Note: *To help ensure the required satellite is found quickly, the CAP 910 uses GPS data recorded during the journey. However, GPS data is only recorded if both the green ignition lead and the turntable are connected to the 12 V power supply (the receiver can remain switched off). If this is not possible, we recommend that you connect the turntable and the ignition signal to the 12 V power supply for approximately 3 minutes before setting up the system. The current GPS data will be provided during this time. Once the ignition signal has been removed, the receiver can be switched on. The CAP 910 now searches for satellites using the exact elevation.*

If the search is unsuccessful, the following message appears:



The search starts automatically after five seconds or if the button was pressed previously. The search may take a few minutes (generally about two minutes). You will first see the following message:



CHANGE OF LOCATION











As soon as the turntable has found the correct satellite, it saves this position. During this process you receive no TV picture. The turntable will then perform an automatic fine adjustment (if the signal level is sufficient, the satellite position will be saved immediately by the turntable). During the fine adjustment you will for the first time receive a TV picture, this however can still “freeze” during the fine adjustment process - whether it does or not is system-dependent.

The set position (of the satellite that was found) is saved and the desired channel appears on the TV screen.

PARK

PARKING THE TURNTABLE

You have four options for “parking” the antenna.

1. The antenna can be moved to park position by pressing the **on/off** button twice.
2. Press the  (green) button. Use the   buttons to select the “Move CAP to park position” line and press the  button to confirm.
3. Press the  button to return to the main menu. The   buttons and  button allow you to call up the submenus (“Settings”, “Antenna Configuration”, “to move the antenna manually”). Use the   buttons to switch to the “Move CAP to park position” item and press the  button to park the antenna.
4. When the ignition is operated, the antenna automatically moves to the park position! However, for this to happen the green wire of the power supply cable must be connected to the ignition and the turntable connected to the power supply (see “Connection Diagram”). Refer to the detailed instructions for this in the CAP unit installation manual.

The antenna is moved to park position, and this is then confirmed.

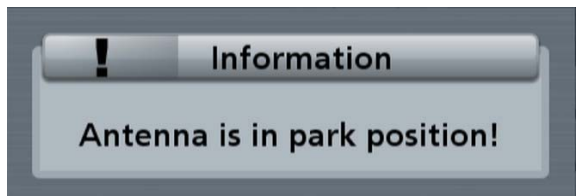
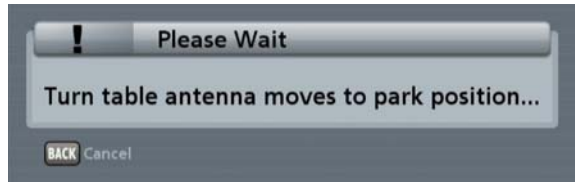

SPECIAL MESSAGES FROM THE TURNTABLE

SYSTEM PROTECTION MESSAGES

The following messages are shown on the screen to protect your reception system and the on-board power supply:

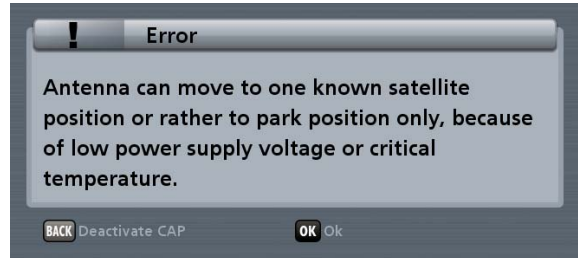

The power supply to the turntable is inadequate (battery voltage below the minimum value). The turntable can still be moved, but communication errors can occur between the UFS 940sw and the turntable (e.g. when scanning for satellites).

If the voltage falls still further, both the following error messages are displayed:

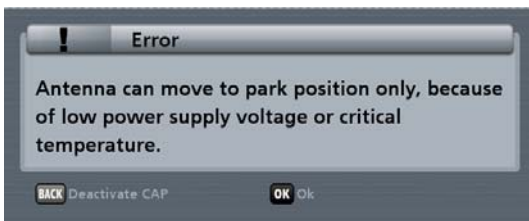

Check the power supply to the turntable and whether it is obstructed (e.g. by a branch). If neither of these causes of faults is displayed, the turntable motor temperature is in the critical range. Allow the turntable to stand for a few minutes in its current position, until the turntable motor temperature has reduced. You can also however move the turntable to the park position and let it cool down there.

Press the **OK** button and the turntable will move to the park position.

Press the **OK** button to confirm the displayed message. The turntable cannot be moved any more. Check the power supply to the turntable.

Note: *The antenna should not be moved whilst the battery is being recharged, to prevent peak loads when turning on.*

SPECIAL MESSAGES FROM THE TURNTABLE



The vehicle ignition was switched on. For safety reasons, the turntable moves into the park position. This operates however only if the green ignition cable for the turntable is connected to the vehicle ignition and the turntable is connected to the power supply! As long as voltage is present at the ignition, the connection to the CAP will remain disabled. This means the CAP cannot be operated.

If the turntable encounters an obstruction, the CAP reverses 10°. This allows the obstacle to be removed more easily.

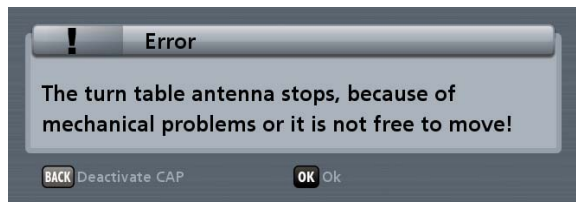

The turntable antenna has reached the mechanical stop or is jammed! Check whether the turntable is obstructed (e.g. by a branch).

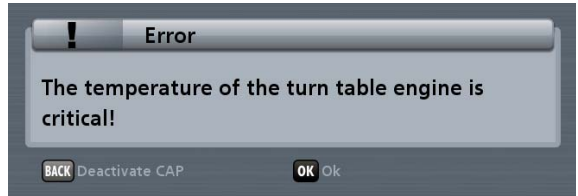

The turntable motor temperature is in the critical range. Allow the turntable to stand for a few minutes in its current position, until the turntable motor temperature has reduced.

SPECIAL MESSAGES FROM THE TURNTABLE

MESSAGES ARISING FROM SOFTWARE PROBLEMS

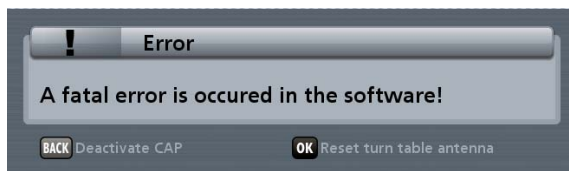

A serious software error has occurred. Reset the turntable in the CAP menu, or contact our service centre.

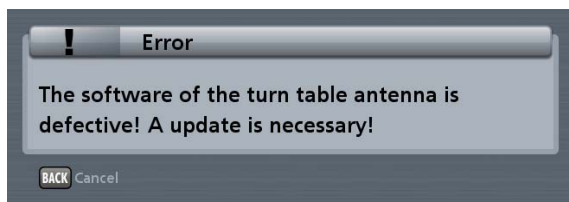

The turntable antenna software is defective. An update is required. Contact our service centre.

FURTHER MESSAGES

This message may also appear if:

- the ignition is switched on
- voltage is present at the ignition cable (green)

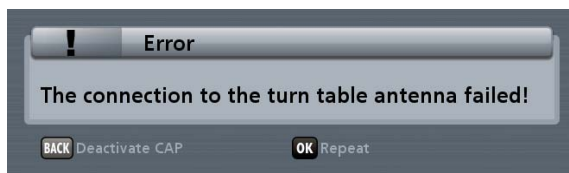

The receiver has lost communication with the turntable. Check the connection between the UFS 940sw and the turntable, the power supply and whether possibly the ignition signal is present at the CAP.

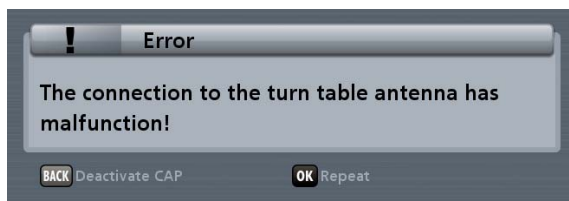

The connection to the turntable is defective. Reset the turntable in the CAP menu, check the connections between the turntable and receiver, or contact our service centre.

SPECIAL MESSAGES FROM THE TURNTABLE

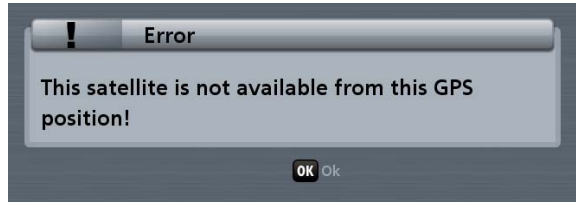

The satellite you have selected cannot be received from your current location, or there may have been changes made using the “CAP settings” menu (see section “CAP menu (turntable antenna settings), CAP settings”), as a result of which the desired satellite cannot be received.

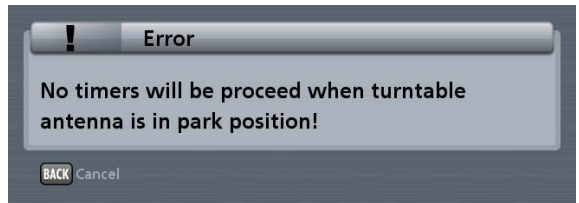

You have used the UFS 940sw to program programmes for recording (see timer list view in the UFS 940sw EPG). If you now move the CAP to the park position, your recordings will not be performed.



To prevent the turntable rotating at a time when it is unsupervised or when rotation might be irritating (e.g. in the middle of the night), a timer can be set. During the timer period the turntable is active only if the UFS 940sw is in operation or is in standby mode.

If the receiver is completely switched off (switched off at the power socket) and/or the turntable is in park position, the turntable will be inactive during the timer period! The same applies if during the first movement the satellite position is not found.

The timer function is currently not yet available in CAP mode!

DECLARATION OF CONFORMITY



EG-Konformitätserklärung / Declaration of Conformity

Hersteller / Manufacturer: **Kathrein-Werke KG**
Anschrift / Address: **Postfach 10 04 44
83004 Rosenheim**
Produktbezeichnung / Product: **Sat-Paket MobiSet 2, 3, 4**
Typenbezeichnung / Type: **CAP 610, CAP 710, CAP 910**
Bestellnummer / Article number: **20310020, 20310021, 20310022**

Die **Kathrein-Werke KG** bestätigt hiermit, dass das bezeichnete Produkt mit den folgenden Richtlinien zur Angleichung der Rechtsvorschriften übereinstimmt.
*The **Kathrein-Werke KG** hereby confirm that the designated product complies with the following directives on the harmonisation of the laws.*

- a) Elektromagnetische Verträglichkeit / EMC (2004/108/EC vom 15.12.2004)
Folgende Normen werden eingehalten / Applied harmonised standards:
EN 55013: 2001 + A1: 2003 + A2: 2006
EN 55020: 2007
- b) Maschinen / Machinery (2006/42/EC vom 17.05.2006)
Folgende Normen werden eingehalten / Applied harmonised standards:
EN ISO 12100-1: 2003, EN ISO 12100-2: 2003
EN ISO 13857: 2008, EN 349: 1993 + A1: 2008
- c) Niederspannungsrichtlinie / Low Voltage Directive (2006/95/EC vom 12.12.2006)
Folgende Normen werden eingehalten / Applied harmonised standards:
EN 60065: 2002 + A1: 2006 + A11: 2008
- d) Energieverbrauchsrelevante Produkte / Energy-related Products (2009/125/EC)
Folgende Verordnungen werden eingehalten / Applied harmonised regulations:
Verordnung (EG) Nr. 1275 / 2008

Entwicklung, Produktion, Qualitätssicherung und Vertrieb basieren auf der Norm EN ISO 9001.
Development, production, quality assurance and marketing are based on the standard EN ISO 9001.

Ort, Datum: Rosenheim, den 26.01.2010
Place, Date:

Rechtsverbindliche Unterschrift:
Binding signature:

i. V.

DISPOSAL INSTRUCTIONS



Electronic equipment is not domestic waste - in accordance with directive 2002/96/EC OF THE EUROPEAN PARLIAMENT AND THE COUNCIL dated 27th January 2003 on used electrical and electronic appliances, it must be disposed of properly.
At the end of its service life, take this device for disposal at a designated public collection point.



Spent batteries are special waste!

Do not throw spent batteries into your domestic waste; take them to a collection point for spent batteries!